

MAGTROL

TM 300 Series

In-Line Torque Transducers



User's Manual

Purchase Record

Please record all model numbers and serial numbers of your Magtrol equipment, along with the general purchase information. The model number and serial number can be found on either a silver identification plate or white label affixed to each unit. Refer to these numbers whenever you communicate with a Magtrol representative about this equipment.

Model Number: _____

Serial Number: _____

Purchase Date: _____

Purchased From: _____

While every precaution has been exercised in the compilation of this document to ensure the accuracy of its contents, Magtrol, Inc./Magtrol SA assumes no responsibility for errors or omissions. Additionally, no liability is assumed for any damages that may result from the use of the information contained within this publication.

COPYRIGHT

Copyright ©2006–2008 Magtrol, Inc. All rights reserved.

Copying or reproduction of all or any part of the contents of this manual without the express permission of Magtrol is strictly prohibited.

TRADEMARKS

LabVIEW™ is a trademark of National Instruments Corporation.

Microsoft® is a registered trademark of Microsoft Corporation.

National Instruments™ is a trademark of National Instruments Corporation.

Windows® is a registered trademark of Microsoft Corporation.

Safety Precautions



WARNING! IN ORDER TO MINIMIZE RISKS, IT IS OF UTMOST IMPORTANCE TO RESPECT THE CURRENT SAFETY STANDARDS WHEN PLANNING, CONFIGURING AND OPERATING THE TORQUE MEASUREMENT DRIVE TRAIN.

1. Make sure that all Magtrol electronic products are earth-grounded, to ensure personal safety and proper operation.
2. Check line voltage before operating electronic equipment.
3. Make sure that all rotating parts are equipped with appropriate safety guards.



Note: Detailed information regarding safety guards can be found in *Section 2.5 – Protective Systems*.

4. Periodically check all connections and attachments.
5. Always wear protective glasses when working with rotating elements.
6. Never wear a necktie or baggy clothes when standing close to rotating elements.
7. Never stand too close or bend over the rotating drive chain.

Revisions to this Manual

The contents of this manual is subject to change without prior notice. Should revisions be necessary, updates to all Magtrol User's Manuals can be found at Magtrol's website at www.magtrol.com/support/manuals.htm?tab=1#TabbedPanels1.

Please compare the date of this manual with the revision date on the web site, then refer to the manual's Table of Revisions for any changes/updates that have been made since this edition.

REVISION DATE

First English edition, revision G – June 2011

Date	Edition	Change	Section(s)
20.06.11	1st Edition - rev. G	Accuracy update for TMB 301 to 313	1.3.1, 1.3.2
26.05.11	1st Edition - rev. F	Overload limit updated	1.3.1, 1.3.2, 1.3.3
04.10.10	1st Edition - rev. E	Added information regarding vertical installation of a TM/TMB	2.1.3
28.07.09	1st Edition - rev. D	Added information regarding connection to an differential amplifier	2.7.3
10.09.08	1st Edition - rev. C	Updated: Figure 2–3 Parastic Forces	2.2
12.18.07	1st Edition - rev. B	New transducer model: TM 309	1.3.2, 2.2.1, 2.2.2 and 2.4.3
01.10.07	1st Edition - rev. A	Added information regarding connection to non-Magtrol electronics.	2.7.3

Table of Contents

SAFETY PRECAUTIONS	I
REVISIONS TO THIS MANUAL	II
REVISION DATE.....	II
TABLE OF REVISIONS	II
TABLE OF CONTENTS	III
TABLE OF FIGURES	IV
PREFACE.....	V
PURPOSE OF THIS MANUAL	V
WHO SHOULD USE THIS MANUAL.....	V
MANUAL ORGANIZATION	V
1. INTRODUCTION	1
1.1 GENERAL INFORMATION.....	1
1.2 DESCRIPTION	1
1.3 DATA SHEETS	2
1.3.1 TM 301 – TM 308.....	2
1.3.2 TM 309 – TM 313.....	6
1.3.3 TM 314 – TM 317.....	12
2. INSTALLATION / CONFIGURATION.....	17
2.1 MOUNTING POSSIBILITIES	17
2.1.1 Suspended Installation	17
2.1.2 Supported Installation	17
2.1.3 TM/TMB in Vertical Installation.....	18
2.2 PARASITIC FORCES.....	18
2.2.1 Radial Forces (Bending)	19
2.2.2 Axial Forces (Thrust)	20
2.3 MEASURING SHAFT VIBRATIONS	21
2.3.1 Permitted Vibrations on Measuring Shaft	21
2.3.2 Torque Signal Conditioning Electronic Circuit.....	23
2.4 MOUNTING LIMITS	24
2.4.1 Dynamic Torque	24
2.4.2 Natural Frequency of Drive Train	24
2.4.3 Natural Measuring Shaft Torsional Frequency	26
2.4.4 Maximum Dynamic Amplitude.....	27
2.5 PROTECTIVE SYSTEMS	27
2.6 ELECTRONIC SIGNAL PROCESSING.....	29
2.6.1 Model 3410 Torque Display.....	29
2.6.2 Model 6400 Torque Transducer Display	30
2.6.3 Model DSP6001 Programmable Dynamometer Controller	31
2.7 ELECTRICAL CONNECTIONS	32
2.7.1 Grounding	32
2.7.2 Connecting Cable.....	33
2.7.3 Connection to Non-Magtrol Electronics	34
3. OPERATING PRINCIPLES.....	36
3.1 TORQUE TRANSDUCER ARCHITECTURE	36

3.1.1	Differential Transformer	37
3.2	SPEED CONDITIONING CHAIN	37
3.3	BUILT-IN SELF-TEST CIRCUIT	37
4.	MAINTENANCE / REPAIR	38
4.1	MAINTENANCE	38
4.2	REPAIR	39
SERVICE INFORMATION		40
RETURNING MAGTROL EQUIPMENT FOR REPAIR AND/OR CALIBRATION		40
Returning Equipment to Magtrol, Inc. (United States)		40
Returning Equipment to Magtrol SA (Switzerland).....		40

TABLE OF FIGURES

1. INTRODUCTION

Figure 1-1	TMB 313 In-Line Torque Transducer	1
------------	---	---

2. INSTALLATION / CONFIGURATION

Figure 2-1	Suspended Installation	17
Figure 2-2	Supported Installation	18
Figure 2-3	Parasitic Forces	18
Figure 2-4	Radial Displacement	21
Figure 2-5	Vibratory Acceleration.....	22
Figure 2-6	SW1 – SW12 Micro-switches and Offset Adjustment Potentiometer	23
Figure 2-7	Simplified Drive Train Model	24
Figure 2-8	Frequency Response Graph.....	25
Figure 2-9	Admissible Dynamic Load.....	27
Figure 2-10	Example of Protective System.....	28
Figure 2-11	Model 3410 Torque Display	29
Figure 2-12	PC-Based System Configuration with Model 3410 Display.....	29
Figure 2-13	Model 6400 Torque Transducer Display	30
Figure 2-14	PC-Based System Configuration with Model 6400 Display.....	30
Figure 2-15	Model DSP6001 Programmable Dynamometer Controller	31
Figure 2-16	PC-Based System Configuration with Model DSP6001 Controller	31
Figure 2-17	Common Grounding	32
Figure 2-18	6-pin Souriau Connector Configuration.....	33
Figure 2-19	14-pin Centronics Connector Configuration.....	33
Figure 2-20	Wiring Diagram for Connection to Non-Magtrol Electronics.....	34
Figure 2-21	ER 107 Pin Configuration.....	35

3. OPERATING PRINCIPLES

Figure 3-1	TM Torque Transducer Principal Elements.....	36
------------	--	----

Preface

PURPOSE OF THIS MANUAL

This manual contains information required for the installation and general use of Magtrol's TM Series In-Line Torque Transducers. To achieve maximum capability and ensure proper use, please read this manual in its entirety before operating the unit. Keep the manual in a safe place for quick reference whenever a question should arise.

WHO SHOULD USE THIS MANUAL

This is written for operators installing a torque transducer as part of a test system that measures the torque on transmission chains. The operator is assumed to have the necessary technical training in electronics and mechanical engineering enabling him to install the in-line torque transducer without risk.

MANUAL ORGANIZATION

This section gives an overview of the structure of the manual and the information contained therein. Some information has been deliberately repeated in different sections of the document to minimize cross-referencing and to facilitate understanding through reiteration.

The structure of the manual is as follows:

- Chapter 1 : INTRODUCTION – Contains the technical data sheets for Magtrol's TM In-Line Torque Transducers, which describe the units and provide detailed technical characteristics.
- Chapter 2 : INSTALLATION / CONFIGURATION – Provides information needed for the setup of the TM Transducers in a test system, and their integration with Magtrol electronic control units.
- Chapter 3 : OPERATING PRINCIPLES – Information pertaining to theory of operation including details about the transducer's architecture, speed conditioning chain and built-in self-test circuit.
- Chapter 4 : MAINTENANCE / REPAIR – Provides information on maintenance and repair procedures, should the need arise.

CONVENTIONS USED IN THIS MANUAL

The following symbols and type styles may be used in this manual to highlight certain parts of the text:



Note: This is intended to draw the operator's attention to complementary information or advice relating to the subject being treated. It introduces information enabling the correct and optimal functioning of the product to be obtained.



CAUTION : THIS IS USED TO DRAW THE OPERATOR'S ATTENTION TO INFORMATION, DIRECTIVES, PROCEDURES, ETC. WHICH, IF IGNORED, MAY RESULT IN DAMAGE BEING CAUSED TO THE MATERIAL BEING USED. THE ASSOCIATED TEXT DESCRIBES THE NECESSARY PRECAUTIONS TO TAKE AND THE CONSEQUENCES THAT MAY ARISE IF THE PRECAUTIONS ARE IGNORED.



WARNING! THIS INTRODUCES DIRECTIVES, PROCEDURES, PRECAUTIONARY MEASURES, ETC. WHICH MUST BE EXECUTED OR FOLLOWED WITH THE UTMOST CARE AND ATTENTION, OTHERWISE THE PERSONAL SAFETY OF THE OPERATOR OR THIRD PARTIES MAY BE PUT AT RISK. THE READER MUST ABSOLUTELY TAKE NOTE OF THE ACCOMPANYING TEXT, AND ACT UPON IT, BEFORE PROCEEDING FURTHER.

1. Introduction

1.1 GENERAL INFORMATION

The TM Series In-Line Torque Transducers represent the new generation of high-precision torque sensors with integrated electronic processing circuitry developed by Magtrol. The TM Series transducers are available in three versions: TMB, TM and TMHS. TMB for all standard applications, TM for high-precision applications and TMHS for high-speed applications.

The TM 300 Series includes transducers with the following torque ratings: 0.1 N·m, 0.2 N·m, 0.5 N·m, 1 N·m, 2 N·m, 5 N·m, 10 N·m, 20 N·m, 50 N·m, 100 N·m, 200 N·m, 500 N·m, 1 000 N·m, 2 000 N·m, 5 000 N·m and 10 000 N·m.

The TM Series In-Line Transducers, together with Magtrol's New TF Series Torque Flange Transducers, offer a wide range of torque measurement requirements for the most demanding applications.

1.2 DESCRIPTION

All TM Series In-Line Torque Transducers consist of a torque measuring shaft and built-in signal processing electronics. These elements, along with two sealed bearings having lifelong lubrication, are all contained in an aluminium housing which also supports the shaft.

The upper part of the unit contains the built-in electronics. This part is sealed according to the IP44 standard and offers protection against splashed water. A Souriau connector allows the torque transducer to be connected to an external signal processing unit—such as the Magtrol 3410 Torque Display—via a special cable assembly.



Figure 1-1 TMB 313 In-Line Torque Transducer

TM Torque Transducers perform the following main functions:

1. Measurement of static and dynamic torque and detection of torque direction.
2. Measurement of the shaft's rotational speed and detection of rotational direction.
3. Self-check.

The transducer's integrated electronic circuitry filters the torque signal and its built-in self-test function checks the operation of the measuring chain. Each transducer also has a built-in temperature compensation circuit. This assures that the accuracy of the measured torque is maintained regardless of operating temperature.

1.3 DATA SHEETS

1.3.1 TM 301 – TM 308

TM 301 – TM 308 In-Line Torque Transducers

FEATURES

- Integrated Torque and Speed Conditioning
- Torque Range: 0.1 N·m to 20 N·m (0.07 lb-ft to 15 lb-ft)
- Accuracy: < 0.1%
- Overload Capacity: 200%
- Overload Limit: 400%
- High Speed Applications: up to 50,000 rpm
- Non-Contact (no slippings)
- No Electronic Components in Rotation
- High Electrical Noise Immunity
- Single DC Power Supply: 20 VDC to 32 VDC
- Immediate Speed Detection
- Adjustable Torque Signal Frequency Limitation
- Built-in Test Function
- Stainless Steel Shaft
- EMC Susceptibility Conforms to European Standards

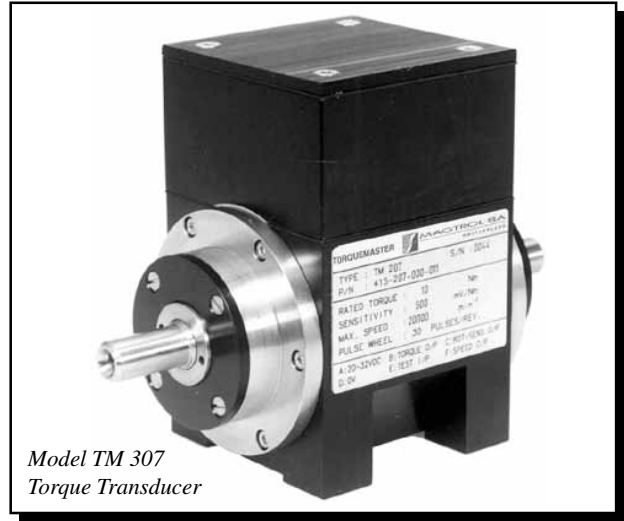

Model TM 307
Torque Transducer

DESCRIPTION

Magtrol’s In-Line Torque Transducers provide extremely accurate torque and speed measurement over a very broad range. Each model has an integrated conditioning electronic module providing a 0 to ±10 VDC torque output and an open collector speed output. Magtrol Torque Transducers are very reliable, providing high overload protection, excellent long term stability and high noise immunity.

All transducer models employ our unique non-contact differential transformer torque measuring technology. This measuring technology offers many benefits, most notably that no electronic components rotate during operation.

To provide customers with several price/performance options, Magtrol offers three torque transducer models: basic accuracy (TMB series), high accuracy (TM series) and high speed with high accuracy (TMHS).

Each transducer consists of a hardened stainless steel shaft with smooth shaft ends, an anodized aluminium housing containing the guide bearings and an electronic measurement conditioner.

The integrated electronic circuit, supplied by single DC voltage, provides torque and speed signals without any additional amplifier. Connections are made by means of a 6-pole male connector mounted on the housing, and fixed mounting is enabled by mounting holes located on the transducer.

APPLICATIONS

TM, TMB and TMHS Series Torque Transducers provide dynamic torque and speed measurement of:

- Propellers - aerospace, marine and helicopter
- Windshield wipers, electrical windows, starters, generators and brakes in automobile industry
- Pumps - water and oil
- Reduction gears and gearboxes
- Clutches
- Motorized valves
- Drills, pneumatic tools and other machine tools

BASIC SYSTEM CONFIGURATION

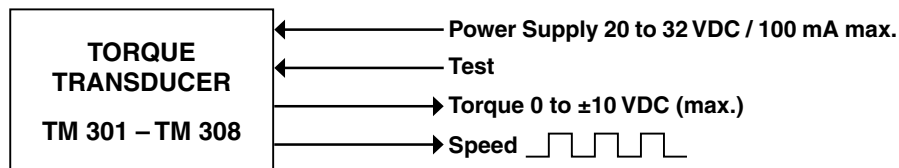

Specifications

TM 301 – TM 308

MODEL RATINGS

The ratings in the following table apply to all Torque Transducer series (TM, TMHS and TMB).

Model	Nominal Rated Torque		Torsional Stiffness		Moment of Inertia		Weight	
	<i>N·m</i>	<i>lb·ft</i>	<i>N·m/rad</i>	<i>lb·ft/rad</i>	<i>kg·m²</i>	<i>lb·ft·s²</i>	<i>kg</i>	<i>lb</i>
301 *	0.1	0.07	29	21	2.50×10^{-5}	1.84×10^{-5}	1.1	2.43
302 *	0.2	0.15	29	21	2.50×10^{-5}	1.84×10^{-5}	1.1	2.43
303	0.5	0.37	66	48	2.55×10^{-5}	1.88×10^{-5}	1.1	2.43
304	1	0.7	145	107	2.82×10^{-5}	2.07×10^{-5}	1.2	2.65
305	2	1.5	290	214	2.91×10^{-5}	2.14×10^{-5}	1.2	2.65
306	5	3.7	725	535	3.08×10^{-5}	2.27×10^{-5}	1.2	2.65
307	10	7.4	1450	1069	2.63×10^{-5}	1.94×10^{-5}	1.2	2.65
308	20	15	2900	2139	2.66×10^{-5}	1.96×10^{-5}	1.2	2.65

* Models 301 and 302 available in TM Series only.

SERIES RATINGS

The ratings in the following table apply to all standard Torque Transducer models 301–308, unless otherwise noted.

Standard Version	TM Series	TMHS Series	TMB Series
TORQUE MEASUREMENT			
Rated Torque (RT)	0 to $\pm 100\%$ of RT		
Maximum Dynamic Torque Peak Value (Overload Capacity)	0 to $\pm 200\%$ of RT		
Maximum Dynamic Torque Without Damage (Overload Limit)	0 to $\pm 400\%$ of RT		
Combined Error of Linearity and Hysteresis to 100% of RT	< $\pm 0.1\%$ of RT (0.2% for TM 301)	< $\pm 0.1\%$ of RT	< $\pm 0.1\%$ of RT
Combined Error of Linearity and Hysteresis from 100% to 200% of RT	< $\pm 0.1\%$ of measured value (0.2% for TM 301)	< $\pm 0.1\%$ of measured value	< $\pm 0.15\%$ of measured value
Temperature Influence on the Zero/Sensitivity: • In the Compensated Range +10 °C to +60 °C • In the Compensated Range -25 °C to +80 °C	< $\pm 0.1\%$ of RT/10K < $\pm 0.2\%$ of RT/10K		< $\pm 0.2\%$ of RT/10K < $\pm 0.4\%$ of RT/10K
Influence of Speed on the Zero Torque Signal	< $\pm 0.01\%$ of RT/1000 rpm		< $\pm 0.02\%$ of RT/1000 rpm
Long-term Stability of Sensitivity	< $\pm 0.05\%$ of RT/year		< $\pm 0.1\%$ of RT/year
SPEED MEASUREMENT			
Rated Range of Use	1 to 20,000 rpm	TMHS 303: 1 to 40,000 rpm TMHS 304-308: 1 to 50,000 rpm	1 to 6,000 rpm
Number of Teeth	60 Z		
Minimum Speed Detection	1 rpm		
ENVIRONMENT			
Storage Temperature Range	-40 °C to +100 °C		
Operating Temperature Range	-40 °C to +85 °C		
Mechanical Shock	according to IEC 68.2.27 / Class D3		
Vibration	according to IEC 68.2.6 / Class D3		
Protection Class	IP 44		
MECHANICAL CHARACTERISTICS			
Shaft Ends	smooth		
Balancing Quality	G1 according to ISO 1940		G2.5 according to ISO 1940
INPUT AND OUTPUT SIGNALS			
Power Supply (max. voltage / current)	20 to 32 VDC / 100 mA		
Torque Output (rated / max.)	$\pm 5 / \pm 10$ VDC		
Filter Cutoff (frequency)	5000, 2500, 1000, 500, 200, 100, 40, 20, 10, 5, 2, 1 Hz		
Speed Output (frequency)	open collector (15 Ω in series), max. 30 VDC, protected against short-circuits		
CONNECTORS			
Counter Connector (female)	optional (P/N 957.11.08.0081)		

Specifications

TM 301 – TM 308

OPERATING PRINCIPLES

The measuring system, based on the principle of a variable, torque-proportional transformer coupling, consists of two concentric cylinders shrunk on the shaft on each side of the shaft's deformation zone, and two concentric coils attached to the housing.

Both cylinders have a circularly disposed coinciding row of slots and rotate with the shaft inside the coils. An alternating current with the frequency of 20 kHz flows through the primary coil. When no torque is applied, the slots on the two cylinders fail to overlap. When torque is applied, the deformation zone undergoes an angular deformation and the slots begin to

overlap. Thus a torque-proportional voltage is on the secondary coil. The conditioning electronic circuit incorporated in the transducer converts the voltage to a nominal torque signal of 0 to ±5 VDC. A low-pass filter (Butterworth/2nd order), adjustable from 5 kHz to 1 Hz, allows tuning of the torque signal frequency limitation.

An optical sensor reads the speed on a toothed path machined directly on the measuring system. The electronic conditioner outputs a frequency signal proportional to the shaft rotational speed. An active circuit compensates the zero and sensitivity temperature drifts within a tolerance of 0.1% / 10 K.

DIMENSIONS

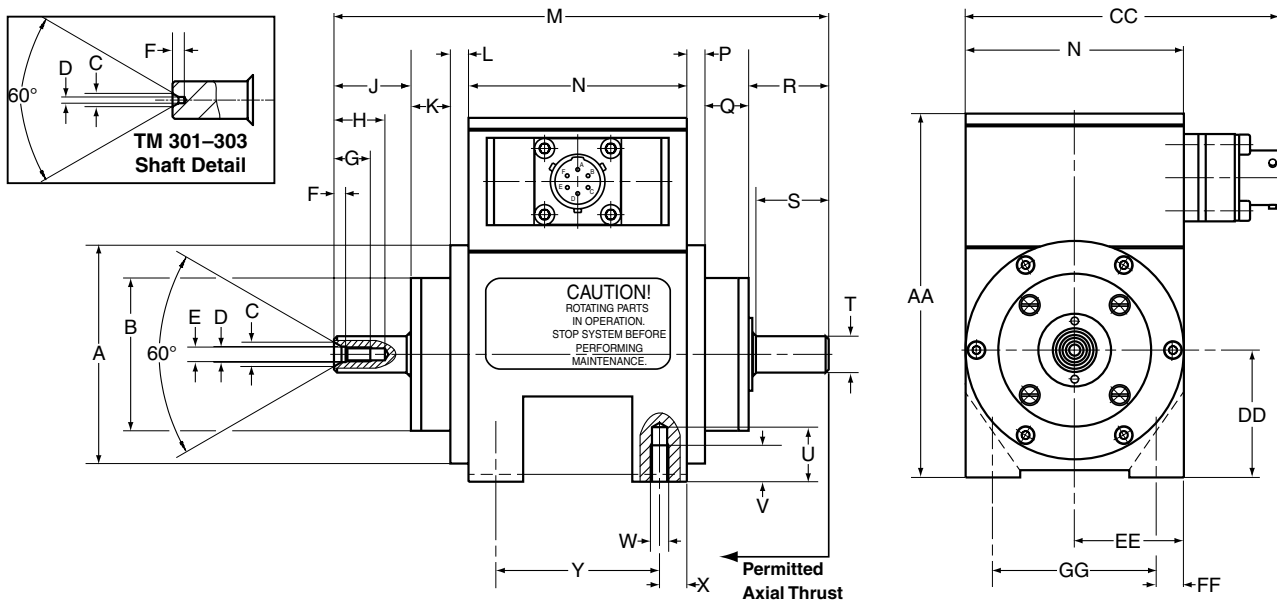

NOTE:

Dimensions are the same for every series (TM, TMHS, TMB).

Original dimensions are in Metric units. Dimensions converted to English have been rounded up to 3 or 4 decimal places.

Model	units	Ø A	Ø B	Ø C	Ø D	E	F	G	H	J	K	L	M	N	P	Q
301-303	mm	60	42g6	2.12	0.1	---	1.9	---	---	13.2	7.8	5	114	60	5	9
	in	2.362	1.6533 1.6526	0.083	0.004	---	0.075	---	---	0.520	0.307	0.197	4.488	2.362	0.197	0.354
304-308	mm	60	42g6	6.7	4.3	M4	3.2	10	14	21.2	10.8	5	136	60	5	12
	in	2.362	1.6533 1.6526	0.264	0.169	M4	0.126	0.394	0.551	0.835	0.425	0.197	5.354	2.362	0.197	0.472

Model	units	R	S	Ø T	U	V	W	X	Y	AA	CC	DD	EE	FF	GG
301-303	mm	14	12	6h6	15	10	M5	7.5	45	100	87	35 ⁰ _{-0.05}	30	7.5	45
	in	0.551	0.472	0.2362 0.2359	0.591	0.394	M5	0.295	1.772	3.937	3.425	1.3779 1.3760	1.181	0.295	1.772
304-308	mm	22	20	10h6	15	10	M5	7.5	45	100	87	35 ⁰ _{-0.05}	30 ±0.02	7.5	45
	in	0.866	0.787	0.3937 0.3933	0.591	0.394	M5	0.295	1.772	3.937	3.425	1.3779 1.3760	1.1819 1.1803	0.295	1.772

Specifications

TM 301 – TM 308

SYSTEM OPTIONS AND ACCESSORIES

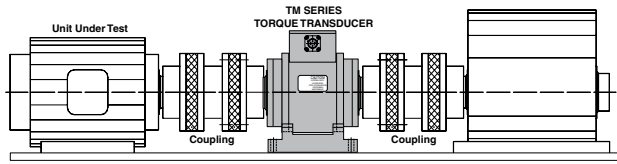

Supported Installation
Mandatory for high speed applications.

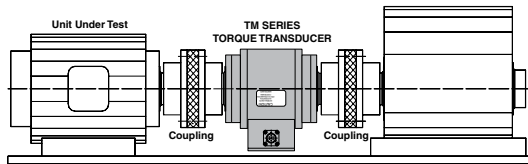

Suspended Installation
For low speed applications only, uses single-element couplings to create a shorter drive train.

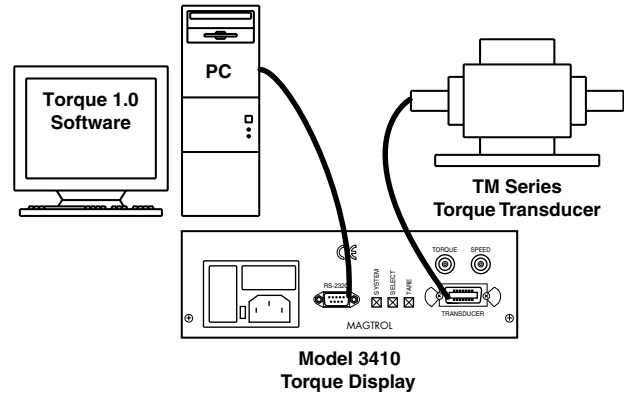

PC-Based System Configuration
Torque Transducer with Model 3410 Display and Torque 1.0 Software

Couplings

When Magtrol TMB, TM and TMHS Series Torque Transducers are to be mounted in a drive train, double-element miniature couplings are the ideal complement, although single-element couplings can be used for low speed applications. Several manufacturers provide adequate couplings for both supported and suspended drive train installations. The criteria for selecting appropriate couplings for torque measurement is as follows:

- High torsional spring rate: Ensures a high torsional stiffness and angular precision (should be greater than three times the torque transducer stiffness)
- Clamping quality (should be self-centering and of adequate strength)
- Speed range
- Balancing quality (according to speed range)
- Alignment capability

The higher the speed of the application, the more care is required in selecting the coupling and assembling (alignment and balancing) the drive train configuration. Your Magtrol sales representative can assist you in choosing the right coupling for your transducer.

Torque Speed Box

Magtrol’s TSB Torque Speed Box allows data acquisition from two torque transducers simultaneously and provides the torque’s analog signal output and speed’s TTL signal output.

Torque Transducer Displays

Magtrol offers two different Torque Displays (Models 3410 and 6400) which supply power to any TM/TMHS/TMB Transducer and display torque, speed and mechanical power. Features include:

- Adjustable English, metric and SI torque units
- Large, easy-to-read vacuum fluorescent display
- Built-in self-diagnostic tests
- Overload indication
- Tare function
- RS-232 interface
- Torque and speed outputs
- Closed-box calibration
- Includes Magtrol Torque 1.0 Software

The Model 6400 Display has the following additional features:

- Pass/fail torque-speed-power testing capabilities
- RS-232 and IEEE-488 interface
- Auxiliary analog input

Torque 1.0 Software

Magtrol’s Torque 1.0 Software is an easy-to-use Windows® executable program, used to automatically collect torque, speed and mechanical power data. The data can be printed, displayed graphically or quickly saved as a Microsoft® Excel spreadsheet. Standard features of Torque 1.0 include: peak torque capture, multi-axes graphing, measured parameter vs. time, adjustable sampling rates and polynomial curve fitting.

Accessories	Model #
Torque Transducer Connector Cable (5/10/20 m)	ER 113

1.3.2 TM 309 – TM 313

TM 309 – TM 313

In-Line Torque Transducers

FEATURES

- Integrated Torque and Speed Conditioning
- Torque Rating: 20 N·m to 500 N·m (37 lb·ft to 369 lb·ft)
- Accuracy: < 0.1%
- Overload Capacity: 200%
- Overload Limit: 400%
- High Speed Applications: up to 32,000 rpm
- Non-Contact (no slippings)
- No Electronic Components in Rotation
- High Electrical Noise Immunity
- Single DC Power Supply: 20 VDC to 32 VDC
- Immediate Speed Detection
- Adjustable Torque Signal Frequency Limitation
- Built-in Test Function
- Stainless Steel Shaft
- EMC Susceptibility Conforms to European Standards

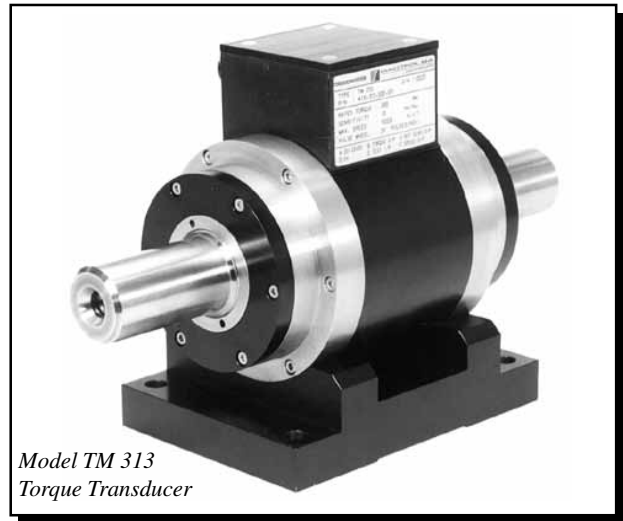

DESCRIPTION

Magtrol’s In-Line Torque Transducers provide extremely accurate torque and speed measurement over a very broad range. Each model has an integrated conditioning electronic module providing a 0 to ±10 VDC torque output and an open collector speed output. Magtrol Torque Transducers are very reliable, providing high overload protection, excellent long term stability and high noise immunity.

All transducer models employ our unique non-contact differential transformer torque measuring technology. This measuring technology offers many benefits, most notably that no electronic components rotate during operation.

To provide customers with several price/performance options, Magtrol offers three torque transducer models: basic accuracy (TMB series), high accuracy (TM series) and high speed with high accuracy (TMHS).

Each transducer consists of a hardened stainless steel shaft with smooth or splined shaft ends, an anodized aluminium housing containing the guide bearings and an electronic measurement conditioner. The integrated electronic circuit, supplied by single

DC voltage, provides torque and speed signals without any additional amplifier. The transducer is a stand-alone measuring chain. Connections are made by means of a 6-pole male connector mounted on the housing. A removable aluminium base—delivered as standard with TM and TMHS models, and as an option for TMB transducers—allows fixed mounting of the transducer.

APPLICATIONS

TM, TMB and TMHS Series Torque Transducers provide dynamic torque and speed measurement of:

- Propellers - aerospace, marine and helicopter
- Windshield wipers, electrical windows, starters, generators and brakes in automobile industry
- Pumps - water and oil
- Reduction gears and gearboxes
- Clutches
- Motorized valves
- Drills, pneumatic tools and other machine tools

BASIC SYSTEM CONFIGURATION

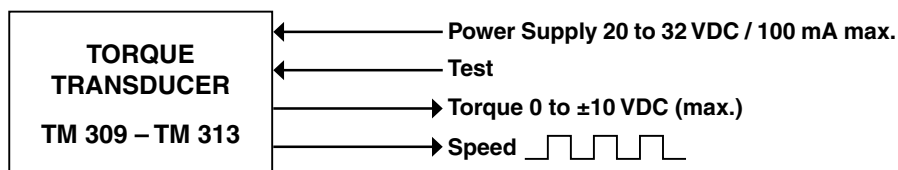

Specifications

TM 309 – TM 313

MODEL RATINGS

The ratings in the following table apply to all Torque Transducer series (TM, TMHS and TMB).

Model	Nominal Rated Torque		Torsional Stiffness		Moment of Inertia		Weight *	
	<i>N·m</i>	<i>lb·ft</i>	<i>N·m/rad</i>	<i>lb·ft/rad</i>	<i>kg·m²</i>	<i>lb·ft·s²</i>	<i>kg</i>	<i>lb</i>
309	20	15	2.4×10^3	1.770×10^3	1.49×10^{-4}	1.03×10^{-4}	2.5	5.51
310	50	37	5.7×10^3	4.204×10^3	1.52×10^{-4}	1.12×10^{-4}	2.5	5.51
311	100	74	1.14×10^4	8.408×10^3	1.55×10^{-4}	1.14×10^{-4}	2.5	5.51
312	200	148	3.82×10^4	2.82×10^4	4.85×10^{-4}	3.57×10^{-4}	4.1	9.04
313	500	369	9.58×10^4	7.07×10^4	5.16×10^{-4}	3.80×10^{-4}	4.4	9.70

* The weight for TMB series transducers ordered without an optional foot mount is slightly lower.

SERIES RATINGS

The ratings in the following table apply to all standard Torque Transducer models 309–313, except where specifically noted.

Standard Version	TM Series	TMHS Series	TMB Series	
TORQUE MEASUREMENT				
Rated Torque (RT)	0 to ±100% of RT			
Maximum Dynamic Torque Peak Value (Overload Capacity)	0 to ±200% of RT			
Maximum Dynamic Torque Without Damage (Overload Limit)	0 to ±400% of RT			
Combined Error of Linearity and Hysteresis to 100% of RT	< ±0.1% of RT	< ±0.1% of RT	< ±0.1% of RT	
Combined Error of Linearity and Hysteresis from 100 to 200% of RT	< ±0.1% of measured value	< ±0.1% of measured value	< ±0.15% of measured value	
Temperature Influence on the Zero/Sensitivity:				
• In the Compensated Range +10 °C to +60 °C	< ±0.1% of RT/10K		< ±0.2% of RT/10K	
• In the Compensated Range -25 °C to +80 °C	< ±0.2% of RT/10K		< ±0.4% of RT/10K	
Influence of Speed on the Zero Torque Signal	< ±0.01% of RT/1000 rpm		< ±0.02% of RT/1000 rpm	
Long-term Stability of Sensitivity	< ±0.05% of RT/year		< ±0.1% of RT/year	
SPEED MEASUREMENT				
Rated Range of Use	models 309–311 models 312–313	1 to 10,000 rpm 1 to 10,000 rpm	1 to 32,000 rpm 1 to 24,000 rpm 1 to 4,000 rpm 1 to 4,000 rpm	
Number of Teeth	60 Z			
Minimum Speed Detection	1 rpm			
ENVIRONMENT				
Storage Temperature Range	-40 °C to +100 °C			
Operating Temperature Range	-40 °C to +85 °C			
Mechanical Shock	according to IEC 68.2.27 / Class D3			
Vibration	according to IEC 68.2.6 / Class D3			
Protection Class	IP 44			
MECHANICAL CHARACTERISTICS				
Shaft Ends	model 309	smooth		
	models 310–311	smooth	smooth	keyway
	models 312–313	smooth or splined	smooth or splined	keyway
Balancing Quality	G1 according to ISO 1940		G2.5 according to ISO 1940	
Foot Support (Base Mount)	included	included	optional	
INPUT AND OUTPUT SIGNALS				
Power Supply (max. voltage / current)	20 to 32 VDC / 100 mA			
Torque Output (rated / max.)	±5 / ±10 VDC			
Filter Cutoff (frequency)	5000, 2500, 1000, 500, 200, 100, 40, 20, 10, 5, 2, 1 Hz			
Speed Output (frequency)	open collector (15 Ω in series), max. 30 VDC, protected against short-circuits			
CONNECTORS				
Counter Connector (female)	optional (P/N 957.11.08.0081)			

Dimensions

TM 309 – TM 313

OPERATING PRINCIPLES

The measuring system, based on the principle of a variable, torque-proportional transformer coupling, consists of two concentric cylinders shrunk on the shaft on each side of the shaft's deformation zone, and two concentric coils attached to the housing.

Both cylinders have a circularly disposed coinciding row of slots and rotate with the shaft inside the coils. An alternating current with the frequency of 20 kHz flows through the primary coil. When no torque is applied, the slots on the two cylinders fail to overlap. When torque is applied, the deformation zone undergoes an angular deformation and the slots begin to overlap.

Thus a torque-proportional voltage is on the secondary coil. The conditioning electronic circuit incorporated in the transducer converts the voltage to a nominal torque signal of 0 to ±5 VDC. A low-pass filter (Butterworth/2nd order), adjustable from 5 kHz to 1 Hz, allows tuning of the torque signal frequency limitation.

An optical sensor reads the speed on a toothed path machined directly on the measuring system. The electronic conditioner outputs a frequency signal proportional to the shaft rotational speed. An active circuit compensates the zero and sensitivity temperature drifts within a tolerance of 0.1% / 10 K.

TRANSDUCERS WITH SMOOTH SHAFT

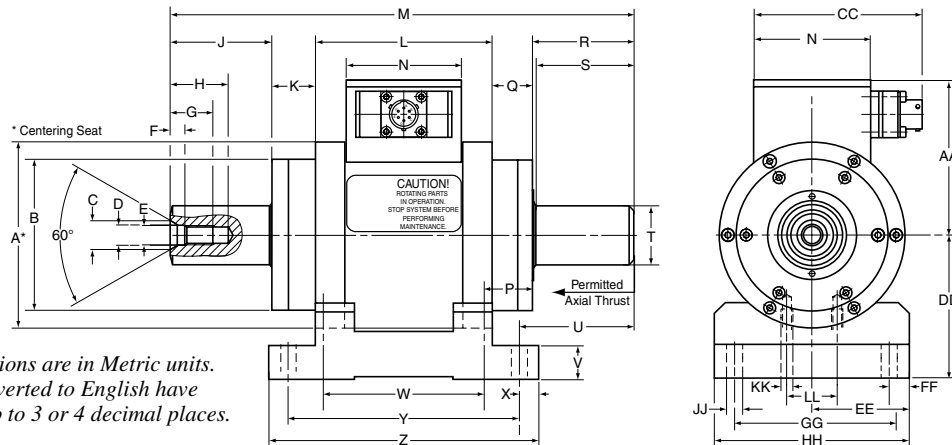

NOTE:
Original dimensions are in Metric units.
Dimensions converted to English have been rounded up to 3 or 4 decimal places.

Model	units	Ø A	Ø B	Ø C	Ø D	E	F	G	H	J	K	L	M	N	P	Q	R	S	Ø T
309/X11	mm	82g6	64	9.6	6.4	M6	5.0	16	21	26.2	16.8	86	170.4	60	20	15	26.4	25	20h6
	in	3.2283 3.2270	2.52	0.378	0.252	M6	0.197	0.63	0.827	1.031	0.661	3.386	6.709	2.362	0.787	0.591	1.039	0.984	0.7874 0.7869
310/X11	mm	82g6	64	9.6	6.4	M6	5.0	16	21	36.2	16.8	86	190.4	60	20	15	36.4	35	20h6
	in	3.2283 3.2270	2.52	0.378	0.252	M6	0.197	0.63	0.827	1.425	0.661	3.386	7.496	2.362	0.787	0.591	1.433	1.378	0.7874 0.7869
311/X11	mm	82g6	64	9.6	6.4	M6	5.0	16	21	41.2	16.8	86	200.4	60	20	15	41.4	40	20h6
	in	3.2283 3.2270	2.52	0.378	0.252	M6	0.197	0.63	0.827	1.622	0.661	3.386	7.89	2.362	0.787	0.591	1.63	1.575	0.7874 0.7869
312/X11	mm	96g6	78	14.9	10.5	M10	7.5	22	30	46.4	22.8	91	228.0	60	25	21	46.8	45	30h6
	in	3.7791 3.7782	3.071	0.587	0.413	M10	0.295	0.866	1.181	1.827	0.898	3.583	8.976	2.362	0.984	0.827	1.842	1.772	1.1811 1.1806
313/X11	mm	96g6	78	14.9	10.5	M10	7.5	22	30	56.4	22.8	91	248.0	60	25	21	56.8	55	30h6
	in	3.7791 3.7782	3.071	0.587	0.413	M10	0.295	0.866	1.181	2.22	0.898	3.583	9.764	2.362	0.984	0.827	2.236	2.165	1.1811 1.1806

Model	units	U	V	W	X	Y	Z	AA	CC	DD	EE	FF	GG	HH	Ø JJ	KK	LL
309/X11	mm	29.4	12	76	10	110	130	74	87	60 (0/-0.05)	45±0.025	8	74	90±0.05	6.6	M5×10	20
	in	1.157	0.472	2.992	0.394	4.331	5.118	2.913	3.425	2.3622 2.3603	1.7726 1.7707	0.315	2.913	3.5453 3.5413	0.260	M5×0.394	0.787
310/X11	mm	39.4	12	76	10	110	130	74	87	60 (0/-0.05)	45±0.025	8	74	90±0.05	7	M5×10	20
	in	1.551	0.472	2.992	0.394	4.331	5.118	2.913	3.425	2.3622 2.3603	1.7726 1.7707	0.315	2.913	3.5453 3.5413	0.276	M5×0.394	0.787
311/X11	mm	44.4	12	76	10	110	130	74	87	60 (0/-0.05)	45±0.025	8	74	90±0.05	7	M5×10	20
	in	1.748	0.472	2.992	0.394	4.331	5.118	2.913	3.425	2.3622 2.3603	1.7726 1.7707	0.315	2.913	3.5453 3.5413	0.276	M5×0.394	0.787
312/X11	mm	53.8	18	83	10	119	139	80	87	75 (0/-0.05)	50±0.025	10	80	100±0.05	9	M6×8	26
	in	2.118	0.709	3.268	0.394	4.685	5.472	3.15	3.425	2.9527 2.9508	1.9695 1.9675	0.394	3.15	3.9390 3.9350	0.354	M6×0.315	1.024
313/X11	mm	63.8	18	83	10	119	139	80	87	75 (0/-0.05)	50±0.025	10	80	100±0.05	9	M6×8	26
	in	2.512	0.709	3.268	0.394	4.685	5.472	3.15	3.425	2.9527 2.9508	1.9695 1.9675	0.394	3.15	3.9390 3.9350	0.354	M6×0.315	1.024

Dimensions

TM 309 – TM 313

TRANSDUCERS WITH SPLINED SHAFT

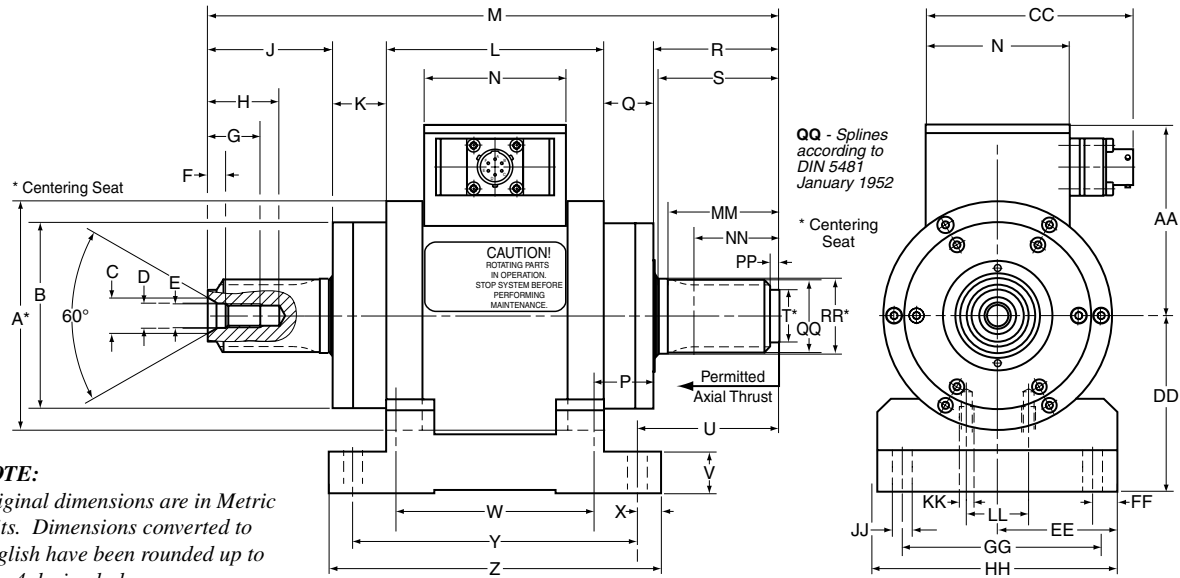

NOTE:
Original dimensions are in Metric units. Dimensions converted to English have been rounded up to 3 or 4 decimal places.

Model	units	Ø A	Ø B	Ø C	Ø D	E	F	G	H	J	K	L	M	N
312/X21	mm	96g6	78	14.9	10.5	M10	7.5	22	30	40.4	22.8	91	216	60
	in	3.7791 3.7782	3.071	0.587	0.413	M10	0.295	0.866	1.181	1.591	0.898	3.583	8.504	2.362
313/X21	mm	96g6	78	14.9	10.5	M10	7.5	22	30	52.4	22.8	91	240	60
	in	3.7791 3.7782	3.071	0.587	0.413	M10	0.295	0.866	1.181	2.063	0.898	3.583	9.449	2.362

Model	units	P	Q	R	S	Ø T	U	V	W	X	Y	Z	AA	CC
312/X21	mm	25	21	40.8	39	22h6	47.8	18	83	10	119	139	80	87
	in	0.984	0.827	1.606	1.535	0.8661 0.8656	1.882	0.709	3.268	0.394	4.685	5.472	3.15	3.425
313/X21	mm	25	21	52.8	51	22h6	59.8	18	83	10	119	139	80	87
	in	0.984	0.827	2.079	2.008	0.8661 0.8656	2.354	0.709	3.268	0.394	4.685	5.472	3.15	3.425

Model	units	DD	EE	FF	GG	HH	Ø JJ	KK	LL	MM	NN	PP	QQ	Ø RR
312/X21	mm	75 ⁰ _{-0.05}	50±0.025	10	80	100±0.05	9	M6×8	26	35	24	4	26×30	31h6
	in	2.9527 2.9508	1.9695 1.9675	0.394	3.15	3.9390 3.9350	0.354	M6×0.315	1.024	1.378	0.945	0.157	26×30	1.2205 1.2198
313/X21	mm	75 ⁰ _{-0.05}	50±0.025	10	80	100±0.05	9	M6×8	26	47	36	4	26×30	31h6
	in	2.9527 2.9508	1.9695 1.9675	0.394	3.15	3.9390 3.9350	0.354	M6×0.315	1.024	1.850	1.417	0.157	26×30	1.2205 1.2198

OPTIONS

Flanges

Flanges are optional for torque transducers with splined shaft ends. Flange drawing is available on request.

Description	Model	P/N
Flange for Model 312/X21	FTM 212	415-212-960-011
Flange for Model 313/X21	FTM 213	415-213-960-011

Dimensions **TM 309 – TM 313**

TMB TRANSDUCERS WITH KEYWAY

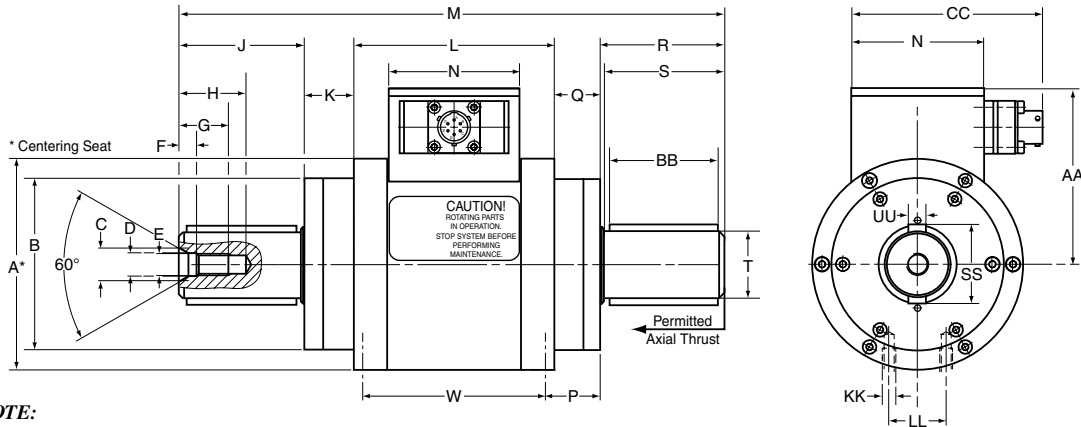

NOTE:
Original dimensions are in Metric units. Dimensions converted to English have been rounded up to 3 or 4 decimal places.

Model	units	Ø A	Ø B	Ø C	Ø D	E	F	G	H	J	K	L	M	P
310/431	mm	82g6	64	9.6	6.4	M6	5.0	16	21	36.2	16.8	86	190.4	20
	in	3.2283 3.2270	2.52	0.378	0.252	M6	0.197	0.63	0.827	1.425	0.661	3.386	7.496	0.787
311/431	mm	82g6	64	9.6	6.4	M6	5.0	16	21	41.2	16.8	86	200.4	20
	in	3.2283 3.2270	2.52	0.378	0.252	M6	0.197	0.63	0.827	1.622	0.661	3.386	7.89	0.787
312/431	mm	96g6	78	14.9	10.5	M10	7.5	22	30	46.4	22.8	91	228.0	25
	in	3.7791 3.7782	3.071	0.587	0.413	M10	0.295	0.866	1.181	1.827	0.898	3.583	8.976	0.984
313/431	mm	96g6	78	14.9	10.5	M10	7.5	22	30	56.4	22.8	91	248.0	25
	in	3.7791 3.7782	3.071	0.587	0.413	M10	0.295	0.866	1.181	2.22	0.898	3.583	9.764	0.984

Model	units	N	Q	R	S	Ø T	W	AA	BB	CC	KK	LL	SS	UU
310/431	mm	60	15	36.4	35	20h6	76	74	32	87	M5x10	20	25	6h9
	in	2.362	0.591	1.433	1.378	0.7874 0.7869	2.992	2.913	1.26	3.425	M5x0.394	0.787	0.984	0.2362 0.2350
311/431	mm	60	15	41.4	40	20h6	76	74	37	87	M5x10	20	25	6h9
	in	2.362	0.591	1.63	1.575	0.7874 0.7869	2.992	2.913	1.457	3.425	M5x0.394	0.787	0.984	0.2362 0.2350
312/431	mm	60	21	46.8	45	30h6	83	80	42	87	M6x8	26	36	8h9
	in	2.362	0.827	1.842	1.772	1.1811 1.1806	3.268	3.15	1.653	3.425	M6x0.315	1.024	1.417	0.3150 0.3135
313/431	mm	60	21	56.8	55	30h6	83	80	52	87	M6x8	26	36	8h9
	in	2.362	0.827	2.236	2.165	1.1811 1.1806	3.268	3.15	2.047	3.425	M6x0.315	1.024	1.417	0.3150 0.3135

OPTIONS

Foot Mount

For foot mount dimensions, refer to U–Z and DD–JJ dimensions of the smooth shaft transducer.

Description	Model	P/N
Foot mount for models 310–311	PTM 310	415-309-950-011
Foot mount for models 312–313	PTM 312	415-312-950-011

System Options

TM 309 – TM 313

SYSTEM OPTIONS AND ACCESSORIES

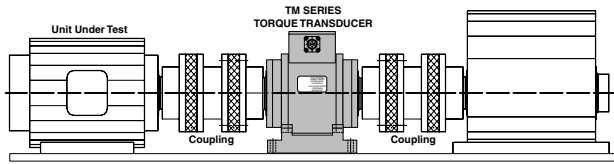

Supported Installation
Mandatory for high speed applications.

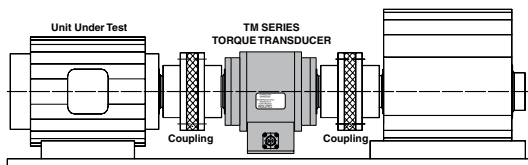

Suspended Installation
For low speed applications only, uses single-element couplings to create a shorter drive train.

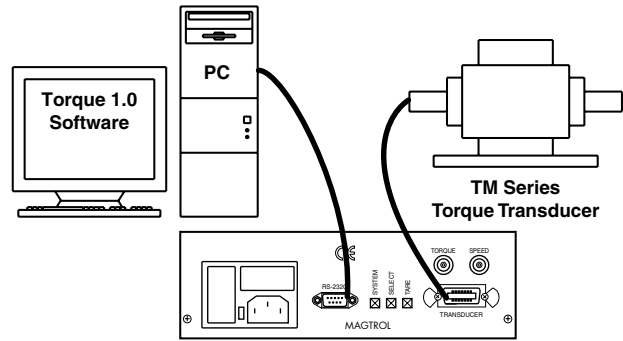

Model 3410 Torque Display
PC-Based System Configuration
Torque Transducer with Model 3410 Display and Torque 1.0 Software

Couplings

When Magtrol TMB, TM and TMHS Series Torque Transducers are to be mounted in a drive train, double-element miniature couplings are the ideal complement, although single-element couplings can be used for low speed applications. Several manufacturers provide adequate couplings for both supported and suspended drive train installations. The criteria for selecting appropriate couplings for torque measurement is as follows:

- High torsional spring rate: Ensures high torsional stiffness & angular precision (should be > 3 times the torque transducer stiffness)
- Clamping quality (should be self-centering & of adequate strength)
- Speed range
- Balancing quality (according to speed range)
- Alignment capability

The higher the speed of the application, the more care is required in selecting the coupling and assembling (alignment and balancing) the drive train configuration. Your Magtrol sales representative can assist you in choosing the right coupling for your transducer.

Torque Speed Box

Magtrol's TSB Torque Speed Box allows data acquisition from two torque transducers simultaneously and provides the torque's analog signal output and speed's TTL signal output.

Torque Transducer Displays

Magtrol offers two different Torque Displays (Models 3410 and 6400) which supply power to any TM/TMHS/TMB Transducer and display torque, speed and mechanical power. Features include:

- Adjustable English, metric and SI torque units
- Large, easy-to-read vacuum fluorescent display
- Built-in self-diagnostic tests
- Overload indication
- Tare function
- RS-232 interface
- Torque and speed outputs
- Closed-box calibration
- Includes Magtrol Torque 1.0 Software

The Model 6400 Display has the following additional features:

- Pass/fail torque-speed-power testing capabilities
- RS-232 and IEEE-488 interface
- Auxiliary analog input

Torque 1.0 Software

Magtrol's Torque 1.0 Software is an easy-to-use Windows[®] executable program, used to automatically collect torque, speed and mechanical power data. The data can be printed, displayed graphically or quickly saved as a Microsoft[®] Excel spreadsheet. Standard features of Torque 1.0 include: peak torque capture, multi-axes graphing, measured parameter vs. time, adjustable sampling rates and polynomial curve fitting.

Accessories	Model #
Torque Transducer Connector Cable (5/10/20 m)	ER 113

1.3.3 TM 314 – TM 317

TM 314 – TM 317

In-Line Torque Transducers

FEATURES

- Integrated Torque and Speed Conditioning
- Torque Rating: 1000 to 10,000 N·m (737 to 7375 lb·ft)
- Accuracy: < 0.1% (depending on model)
- Overload Capacity: 200%
- Overload Limit: 400% (TM 317 up to 280%)
- High Speed Applications: up to 16,000 rpm
- Non-Contact (no slippings)
- No Electronic Components in Rotation
- High Electrical Noise Immunity
- Single DC Power Supply: 20 VDC to 32 VDC
- Immediate Speed Detection
- Adjustable Torque Signal Frequency Limitation
- Built-in Test Function
- Stainless Steel Shaft
- EMC Susceptibility Conforms to European Standards

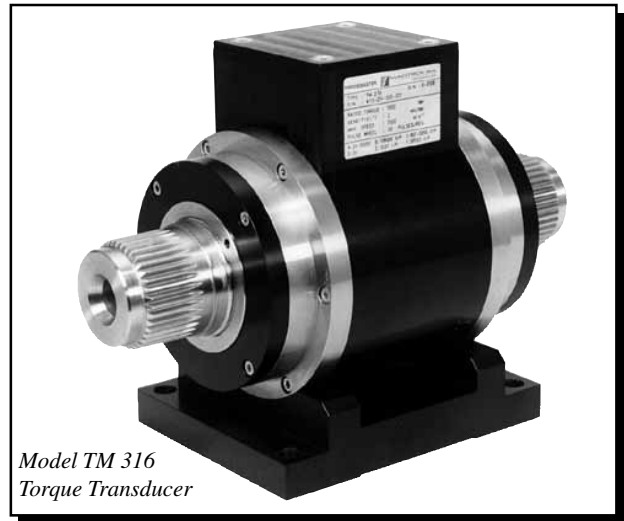

Model TM 316
Torque Transducer

DESCRIPTION

Magtrol’s In-Line Torque Transducers provide extremely accurate torque and speed measurement over a very broad range. Each model has an integrated conditioning electronic module providing a 0 to ±10 VDC torque output and an open collector speed output. Magtrol Torque Transducers are very reliable, providing high overload protection, excellent long term stability and high noise immunity.

All transducer models employ our unique non-contact differential transformer torque measuring technology. This measuring technology offers many benefits, most notably that no electronic components rotate during operation.

To provide customers with several price/performance options, Magtrol offers two torque transducer models: high accuracy (TM series) and high speed with high accuracy (TMHS).

Each transducer consists of a hardened stainless steel shaft with smooth or splined shaft ends, an anodized aluminium housing containing the guide bearings and an electronic measurement conditioner. The integrated electronic circuit,

supplied by single DC voltage, provides torque and speed signals without any additional amplifier. The transducer is a stand-alone measuring chain. Connections are made by means of a 6-pole male connector mounted on the housing. A removable aluminium base, delivered as standard, allows fixed mounting of the transducer.

APPLICATIONS

TM and TMHS Series Torque Transducers provide dynamic torque and speed measurement of:

- Propellers - aerospace, marine and helicopter
- Windshield wipers, electrical windows, starters, generators and brakes in automobile industry
- Pumps - water and oil
- Reduction gears and gearboxes
- Clutches
- Motorized valves
- Drills, pneumatic tools and other machine tools

BASIC SYSTEM CONFIGURATION

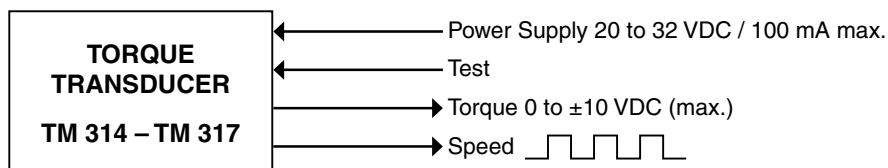

Specifications

TM 314 – TM 317

MODEL RATINGS

The ratings in the following table apply to both Torque Transducer series (TM and TMHS).

Model	Nominal Rated Torque		Torsional Stiffness		Moment of Inertia		Weight	
	<i>N-m</i>	<i>lb-ft</i>	<i>N-m/rad</i>	<i>lb-ft/rad</i>	<i>kg-m²</i>	<i>lb-ft-s²</i>	<i>kg</i>	<i>lb</i>
314 / X21	1,000	737	3.28×10^5	2.419×10^6	3.01×10^{-3}	2.21×10^{-3}	9.2	20.3
314 / X31							9.9	21.8
315 / X21	2,000	1,475	6.56×10^5	4.838×10^6	3.30×10^{-3}	2.43×10^{-3}	10.1	22.3
315 / X31							10.8	23.8
316 / X21	5,000	3,687	1.94×10^6	1.4×10^7	9.95×10^{-3}	7.32×10^{-3}	20.0	44.1
317 / X21	10,000	7,375	2.26×10^6	1.7×10^7	1.18×10^{-2}	8.66×10^{-3}	22.3	49.2

SERIES RATINGS

The ratings in the following table apply to all standard Torque Transducer models 314–317.

Standard Version	Model	TM Series	TMHS Series
TORQUE MEASUREMENT			
Rated Torque (RT)	314–317	0 to $\pm 100\%$ of RT	
Maximum Dynamic Torque Peak Value (Overload Capacity)	314–317	0 to $\pm 200\%$ of RT	
Maximum Dynamic Torque Without Damage (Overload Limit)	314–316	0 to $\pm 400\%$ of RT	
	317	0 to $\pm 280\%$ of RT	
Combined Error of Linearity and Hysteresis to 100% of RT	314–316	$< \pm 0.1\%$ of RT	
	317	$< \pm 0.15\%$ of RT	
Combined Error of Linearity and Hysteresis from 100 to 200% of RT	314–316	$< \pm 0.1\%$ of measured value	
	317	$< \pm 0.15\%$ of measured value	
Temperature Influence on the Zero/Sensitivity: • In the Compensated Range +10 °C to +60 °C • In the Compensated Range -25 °C to +80 °C	314–317	$< \pm 0.1\%$ of RT/10K	
		$< \pm 0.2\%$ of RT/10K	
Influence of Speed on the Zero Torque Signal	314–317	$< \pm 0.01\%$ of RT/1000 rpm	
Long-term Stability of Sensitivity	314–317	$< \pm 0.05\%$ of RT/year	
SPEED MEASUREMENT			
Rated Range of Use	314–315	1 to 7,000 rpm	1 to 16,000 rpm
	316–317	1 to 5,000 rpm	1 to 12,000 rpm
Number of Teeth	314–317	60 Z	
Minimum Speed Detection	314–317	1 rpm	
ENVIRONMENT			
Storage Temperature Range	314–317	-40 °C to +100 °C	
Operating Temperature Range	314–317	-40 °C to +85 °C	
Mechanical Shock	314–317	according to IEC 68.2.27 / Class D3	
Vibration	314–317	according to IEC 68.2.6 / Class D3	
Protection Class	314–317	IP 44	
MECHANICAL CHARACTERISTICS			
Shaft Ends	314–315	splined or keyway	
	316–317	splined	
Balancing Quality	314–317	G1 according to ISO 1940	
Foot Support (Base Mount)	314–317	included	
INPUT AND OUTPUT SIGNALS			
Power Supply (max. voltage / current)	314–317	20 to 32 VDC / 100 mA	
Torque Output (rated / max.)	314–317	$\pm 5 / \pm 10$ VDC	
Filter Cutoff (frequency)	314–317	5000, 2500, 1000, 500, 200, 100, 40, 20, 10, 5, 2, 1 Hz	
Speed Output (frequency)	314–317	open collector (15 Ω in series), max. 30 VDC, protected against short-circuits	
CONNECTORS			
Counter Connector (female)	314–317	optional (P/N 957.11.08.0081)	

Dimensions

TM 314 – TM 317

OPERATING PRINCIPLES

The measuring system, based on the principle of a variable, torque-proportional transformer coupling, consists of two concentric cylinders shrunk on the shaft on each side of the shaft's deformation zone, and two concentric coils attached to the housing.

Both cylinders have a circularly disposed coinciding row of slots and rotate with the shaft inside the coils. An alternating current with the frequency of 20 kHz flows through the primary coil. When no torque is applied, the slots on the two cylinders fail to overlap. When torque is applied, the deformation zone undergoes an angular deformation and the slots begin to overlap.

Thus a torque-proportional voltage is on the secondary coil. The conditioning electronic circuit incorporated in the transducer converts the voltage to a nominal torque signal of 0 to ±5 VDC. A low-pass filter (Butterworth/2nd order), adjustable from 5 kHz to 1 Hz, allows tuning of the torque signal frequency limitation.

An optical sensor reads the speed on a toothed path machined directly on the measuring system. The electronic conditioner outputs a frequency signal proportional to the shaft rotational speed. An active circuit compensates the zero and sensitivity temperature drifts within a tolerance of 0.1% / 10 K.

TM AND TMHS TRANSDUCCERS WITH KEYWAY SHAFT

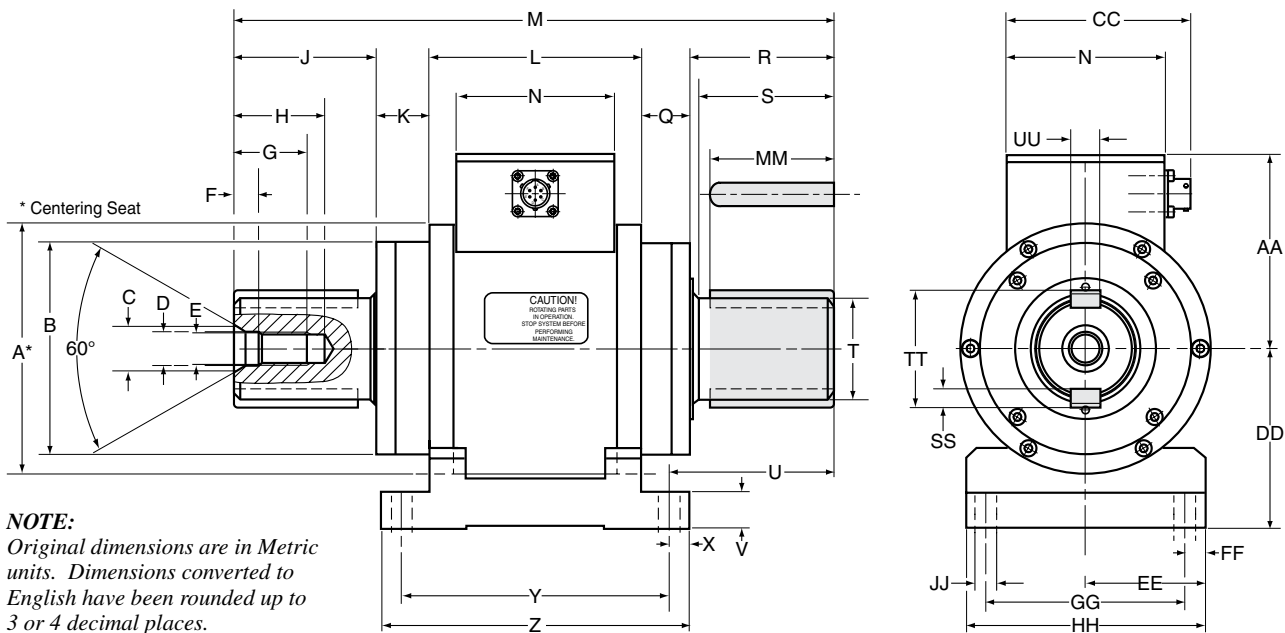

NOTE:
Original dimensions are in Metric units. Dimensions converted to English have been rounded up to 3 or 4 decimal places.

Model	units	Ø A	Ø B	Ø C	Ø D	E	F	G	H	J	K	L	M	N	Q	R	S	Ø T	U
314/X31	mm	125g6	106	23	17	M16	12	36	45	67.7	26.8	106	294	80	25	68.5	65	50h6	79.5
	in	4.9207 4.9197	4.173	0.906	0.669	M16	0.472	1.417	1.772	2.665	1.055	4.173	11.575	3.150	0.984	2.697	2.559	1.9685 1.9679	3.130
315/X31	mm	125g6	106	23	17	M16	12	36	45	87.7	26.8	106	334	80	25	88.5	85	50h6	99.5
	in	4.9207 4.9197	4.173	0.906	0.669	M16	0.472	1.417	1.772	3.453	1.055	4.173	13.150	3.150	0.984	3.484	3.346	1.9685 1.9679	3.917

Model	units	V	X	Y	Z	AA	CC	DD	EE	FF	GG	HH	Ø JJ	MM	SS	TT	UU
314/X31	mm	18	10	134	154	98	93	90 ^(0/-0.05)	60±0.025	10	100	120±0.05	11	60.0	9h11	57	14h9
	in	0.709	0.394	5.276	6.063	3.858	3.661	3.5433 3.5414	2.3632 2.3612	0.394	3.937	4.7264 4.7224	0.433	2.362	0.3543 0.3508	2.244	0.5512 0.5495
315/X31	mm	18	10	134	154	98	93	90 ^(0/-0.05)	60±0.025	10	100	120±0.05	11	59.7	9h11	57	14h9
	in	0.709	0.394	5.276	6.063	3.858	3.661	3.5433 3.5414	2.3632 2.3612	0.394	3.937	4.7264 4.7224	0.433	2.350	0.3543 0.3508	2.244	0.5512 0.5495

Dimensions

TM 314 – TM 317

TM AND TMHS TRANSDUCCERS WITH SPLINED SHAFT

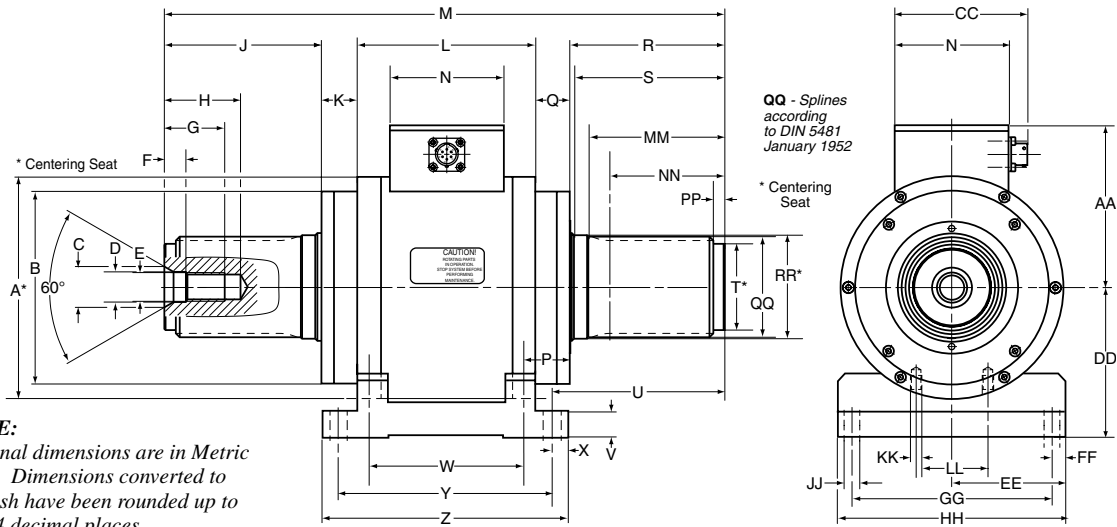

NOTE:
Original dimensions are in Metric units. Dimensions converted to English have been rounded up to 3 or 4 decimal places.

Model	units	Ø A	Ø B	Ø C	Ø D	E	F	G	H	J	K	L	M	N	P	Q	R	S	Ø T	U	V
314/X21	mm	125g6	106	23	17	M16	12	36	45	50.7	26.8	106	260	80	32	25	51.5	48	44h6	62.5	18
	in	4.9207 4.9197	4.173	0.906	0.669	M16	0.472	1.417	1.772	1.996	1.055	4.173	10.236	3.150	1.260	0.984	2.028	1.890	1.7323 1.7317	2.461	0.709
315/X21	mm	125g6	106	23	17	M16	12	36	45	70.7	26.8	106	300	80	32	25	71.5	68	44h6	82.5	18
	in	4.9207 4.9197	4.173	0.906	0.669	M16	0.472	1.417	1.772	2.784	1.055	4.173	11.811	3.150	1.260	0.984	2.815	2.677	1.7323 1.7317	3.248	0.709
316/X21	mm	155g6	135	28.4	21	M20	15	42	53	82.7	25.8	124	340	80	33	24	83.5	80	55h6	94.5	18
	in	6.1018 6.1008	5.315	1.118	0.827	M20	0.591	1.654	2.087	3.256	1.016	4.882	13.386	3.150	1.299	0.945	3.287	3.150	2.1654 2.1646	3.721	0.709
317/X21	mm	155g6	135	28.4	21	M20	15	42	53	107.7	25.8	124	390	80	33	24	108.5	105	60h6	119.5	18
	in	6.1018 6.1008	5.315	1.118	0.827	M20	0.591	1.654	2.087	4.240	1.016	4.882	15.354	3.150	1.299	0.945	4.272	4.134	2.3622 2.3615	4.705	0.709

Model	units	W	X	Y	Z	AA	CC	DD	EE	FF	GG	HH	Ø JJ	KK	LL	MM	NN	PP	QQ	Ø RR
314/X21	mm	92	10	134	154	98	93	90 ^(0, -0.05)	60±0.025	10	100	120±0.05	11	M8x10	36	42	28	8	45x50	52h6
	in	3.622	0.394	5.276	6.063	3.858	3.661	3.5433 3.5414	2.3632 2.3612	0.394	3.937	4.7264 4.7224	0.433	M8x 0.394	1.417	1.654	1.102	0.315	45x50	2.0472 2.0465
315/X21	mm	92	10	134	154	98	93	90 ^(0, -0.05)	60±0.025	10	100	120±0.05	11	M8x10	36	62	48	8	45x50	52h6
	in	3.622	0.394	5.276	6.063	3.858	3.661	3.5433 3.5414	2.3632 2.3612	0.394	3.937	4.7264 4.7224	0.433	M8x 0.394	1.417	2.441	1.890	0.315	45x50	2.0472 2.0465
316/X21	mm	106	10	150	170	113.5	93	105 ^(0, -0.05)	80±0.025	10	140	160±0.05	11	M8x10	50	70	50	8	60x65	70h6
	in	4.173	0.394	5.905	6.693	4.468	3.661	4.1338 4.1319	3.1506 3.1486	0.394	5.512	6.3012 6.2972	0.433	M8x 0.394	1.968	2.756	1.968	0.315	60x65	2.7559 2.7552
317/X21	mm	106	10	150	170	113.5	93	105 ^(0, -0.05)	80±0.025	10	140	160±0.05	11	M8x10	50	95	80	8	65x70	72h6
	in	4.173	0.394	5.905	6.693	4.468	3.661	4.1338 4.1319	3.1506 3.1486	0.394	5.512	6.3012 6.2972	0.433	M8x 0.394	1.968	3.740	3.150	0.315	65x70	2.8346 2.8339

OPTIONS

Flanges

Flanges are optional for torque transducers with splined shaft ends. Flange drawing is available on request.

Description	Model	P/N
Flange for Model 314/X21	FTM 214	415-214-960-011
Flange for Model 315/X21	FTM 215	415-215-960-011
Flange for Model 316/X21	FTM 216	415-216-960-011
Flange for Model 317/X21	FTM 217	415-217-960-011

System Options

TM 314 – TM 317

SYSTEM OPTIONS AND ACCESSORIES

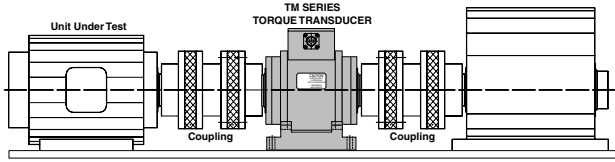

Supported Installation
Mandatory for high speed applications.

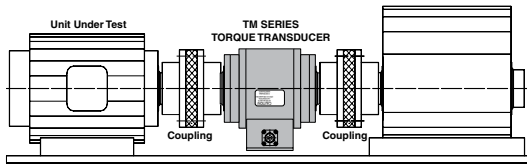

Suspended Installation
For low speed applications only, uses single-element couplings to create a shorter drive train.

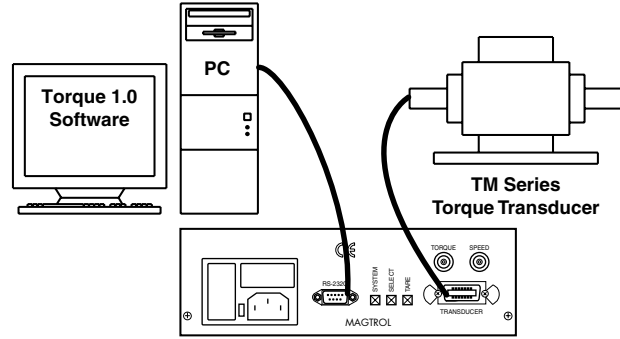

PC-Based System Configuration
Torque Transducer with Model 3410 Display and Torque 1.0 Software

Couplings

When Magtrol TMB, TM and TMHS Series Torque Transducers are to be mounted in a drive train, double-element miniature couplings are the ideal complement, although single-element couplings can be used for low speed applications. Several manufacturers provide adequate couplings for both supported and suspended drive train installations. The criteria for selecting appropriate couplings for torque measurement is as follows:

- High torsional spring rate: Ensures high torsional stiffness & angular precision (should be > 3 times the torque transducer stiffness)
- Clamping quality (should be self-centering & of adequate strength)
- Speed range
- Balancing quality (according to speed range)
- Alignment capability

The higher the speed of the application, the more care is required in selecting the coupling and assembling (alignment and balancing) the drive train configuration. Your Magtrol sales representative can assist you in choosing the right coupling for your transducer.

Torque Speed Box

Magtrol’s TSB Torque Speed Box allows data acquisition from two torque transducers simultaneously and provides the torque’s analog signal output and speed’s TTL signal output.

Torque Transducer Displays

Magtrol offers two different Torque Displays (Models 3410 and 6400) which supply power to any TM/TMHS/TMB Transducer and display torque, speed and mechanical power. Features include:

- Adjustable English, metric and SI torque units
- Large, easy-to-read vacuum fluorescent display
- Built-in self-diagnostic tests
- Overload indication
- Tare function
- RS-232 interface
- Torque and speed outputs
- Closed-box calibration
- Includes Magtrol Torque 1.0 Software

The Model 6400 Display has the following additional features:

- Pass/fail torque-speed-power testing capabilities
- RS-232 and IEEE-488 interface
- Auxiliary analog input

Torque 1.0 Software

Magtrol’s Torque 1.0 Software is an easy-to-use Windows® executable program, used to automatically collect torque, speed and mechanical power data. The data can be printed, displayed graphically or quickly saved as a Microsoft® Excel spreadsheet. Standard features of Torque 1.0 include: peak torque capture, multi-axes graphing, measured parameter vs. time, adjustable sampling rates and polynomial curve fitting.

Accessories	Model #
Torque Transducer Connector Cable (5/10/20 m)	ER 113

2. Installation / Configuration

2.1 MOUNTING POSSIBILITIES

Magtrol TM Series Torque In-Line Torque Transducers must, above all, be considered precision measuring instruments and not torque transmission components. The transducer model and the alignment precision highly influence the measuring precision as well as the operating life of the transducer, especially of the bearings and couplings.

There are two different ways of mounting TM Torque Transducers: suspended and supported installation.

2.1.1 SUSPENDED INSTALLATION

Both the measuring shaft and torque transducer housing are supported by the driving and driven machine shafts via couplings (see *figure 2-1*). In this configuration, couplings offering only one degree of freedom are adequate to avoid a hyperstatic mounting.

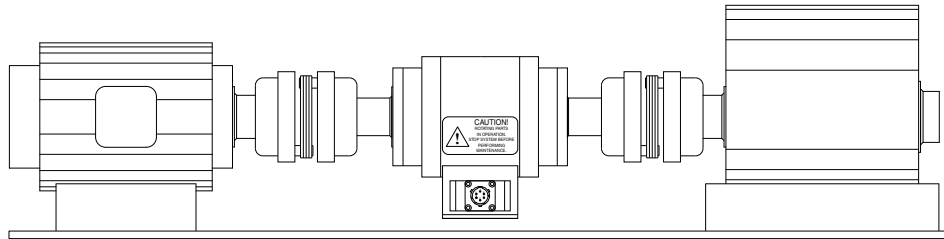

Figure 2-1 Suspended Installation

2.1.1.1 Advantages

- Single-element couplings are less expensive than double-element couplings.
- Shorter drive train leading to a higher torsional resonance frequency (as compared to double-element couplings).

2.1.1.2 Disadvantages

- Increase of radial play as the torque transducer is not directly fixed to the test bench. Consequently, the critical speed is lower than with a supported installation.



Note: The low friction torque generated by the bearings, as well as the weight of the built-in electronic housing, results in only the shaft being driven by the rotating system.

2.1.2 SUPPORTED INSTALLATION

The measuring shaft is supported by the torque sensor housing, which itself is fixed to the test bench frame by means of a support unit (see *Figure 2-2*). Here, couplings with two degrees of freedom must be used in order to avoid hyperstatic mountings.

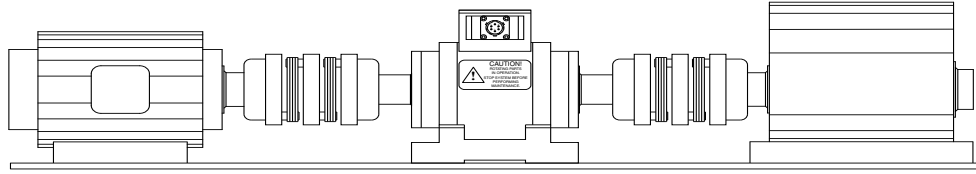

Figure 2-2 Supported Installation

2.1.2.1 Advantages

- Increased critical speed due to less shaft bending.

2.1.2.2 Disadvantages

- Longer overall length of the test bench due to the use of double-element couplings.
- Increased price due to the higher price of double-element couplings.



Note : Supported installations are required when larger misalignments between the different elements of the system are a possibility, as well as with high rotational speeds.

High-performance couplings can be realized by mounting flanges directly onto a splined torque transducer shaft. (Not available on all models.)

2.1.3 TM/TMB IN VERTICAL INSTALLATION

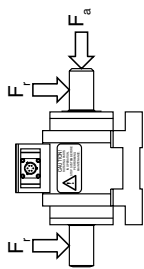

Correct!

Electronic and connector left from shaft when looking into the connector!

Caution: Please refer to manuals for max. acceptable F_a force!

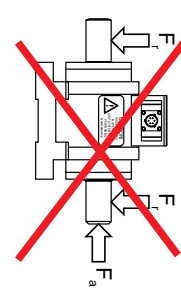

Wrong!

2.2 PARASITIC FORCES

Incorrectly mounted torque transducers can generate parasitic forces on the measuring shaft in radial (F_r) and axial direction (F_a) (see Figure 2-3).

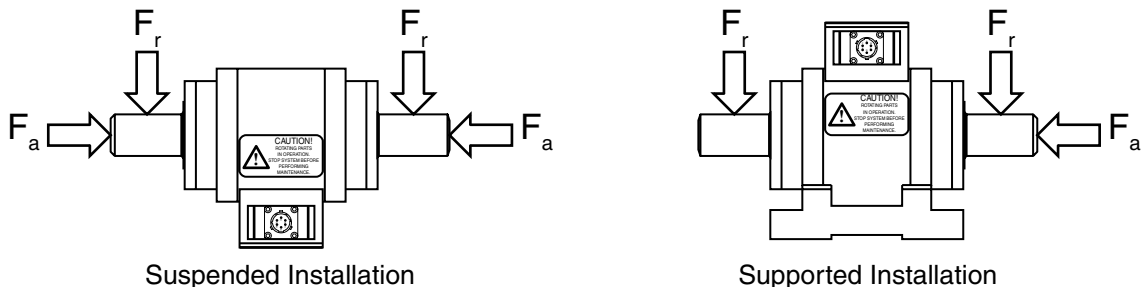

Figure 2-3 Parasitic Forces

2.2.1 RADIAL FORCES (BENDING)

Radial forces (F_r in *Figure 2–3*) generate a bending momentum in the measuring shaft resulting in displacement of its center of gravity. This disequilibrium will load the shaft periodically with a frequency proportional to the speed of rotation. This effect is particularly noticeable at high speeds.



CAUTION : IN EXTREME CASES, A HIGH BENDING FORCE MAY CAUSE PERMANENT DEFORMATION OF THE MEASURING SHAFT, LEADING TO FALSE MEASURING RESULTS.

The following table lists the maximum radial forces F_r allowed for TMB, TM and TMHS Series torque transducer shafts in suspended and supported installations.

Model	F_r max. (Suspended installations)	F_r max. (Supported installations)	
		TM / TMB (if available)	TMHS
	<i>N</i>	<i>N</i>	<i>N</i>
TM 301	*	8	N/A
TM 302	*	16	N/A
TM 303	*	25	25
TM 304	20	50	50
TM 305	40	80	80
TM 306	70	120	120
TM 307	60	120	120
TM 308	80	160	120
TM 309	60	150	150
TM 310	120	300	280
TM 311	200	410	280
TM 312	300	570	420
TM 313	500	550	410
TM 314	800	900	680
TM 315	1100	850	640
TM 316	2200	1460	1090
TM 317	2200	1300	980

* *Suspended installation is not recommended for these models.*

2.2.2 AXIAL FORCES (THRUST)

In suspended installations, pure thrust forces (F_a in *figure 2–3*) have practically no effect on the measurement results, as they do not provoke any deformation of the shaft that could influence the measurement.

In supported installations, axial thrust forces produce a strain on the bearings. This leads to premature wear of the bearings and an increase of the residual torque. In this case, the maximum allowed axial force for the transducer is lower than the allowed force in the case of suspended installation.



Note: It is important to avoid the simultaneous application of radial and axial forces on the measuring shaft of a transducer, especially with supported installations.

The following table lists the maximal axial forces F_a allowed for TMB, TM and TMHS Series transducer shafts in suspended and supported installations.

Model	F_a max. (Suspended installations)	F_a max. (Supported installations)
	<i>N</i>	<i>N</i>
TM 301	600	35
TM 302	600	35
TM 303	1 000	35
TM 304	1 100	100
TM 305	1 500	100
TM 306	2 500	100
TM 307	3 500	100
TM 308	4 000	100
TM 309	4 500	120
TM 310	6 000	120
TM 311	10 000	120
TM 312	20 000	150
TM 313	30 000	150
TM 314	60 000	200
TM 315	80 000	200
TM 316	150 000	200
TM 317	150 000	200

2.3 MEASURING SHAFT VIBRATIONS

The presence of radial misalignment in the configuration will give rise to periodic radial displacement of the torque measuring shaft. This, in turn, will induce parasitic vibrations influencing the torque measuring signal.

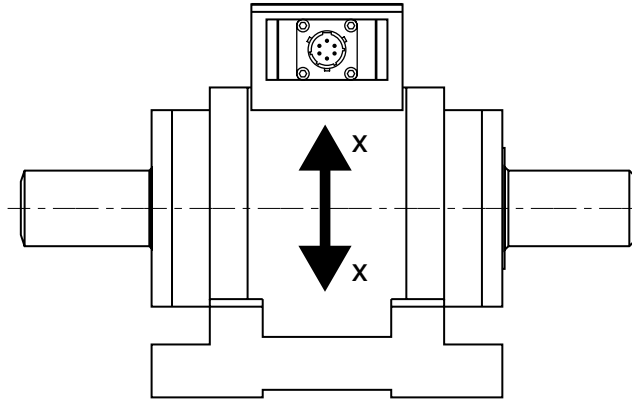

Figure 2-4 Radial Displacement

2.3.1 PERMITTED VIBRATIONS ON MEASURING SHAFT

The periodic displacement of the measuring shaft generates vibrations. These vibrations express themselves in either speed (in m/s) or acceleration (in m/s² or g).



Note: "g" is normally used as a unit for acceleration. It represents the Earth's acceleration of 9,81 m/s², often rounded up to 10 m/s².

Both of these parameters depend on the radial displacement and the speed of the shaft. The formulas used to calculate this speed and acceleration are as follows:

$$\begin{aligned} \text{Speed:} \quad & v = 2 \cdot \pi \cdot n \cdot x \text{ [m/s]} \\ \text{Acceleration:} \quad & a = 4 \cdot \pi^2 \cdot n^2 \cdot x \text{ [m/s}^2\text{]} \end{aligned}$$

"x" represents radial displacement, expressed in meters (see Figure 2-4)

"n" represents rotational speed, in s⁻¹

The vibratory acceleration of the above is illustrated with the graph in Figure 2-5.

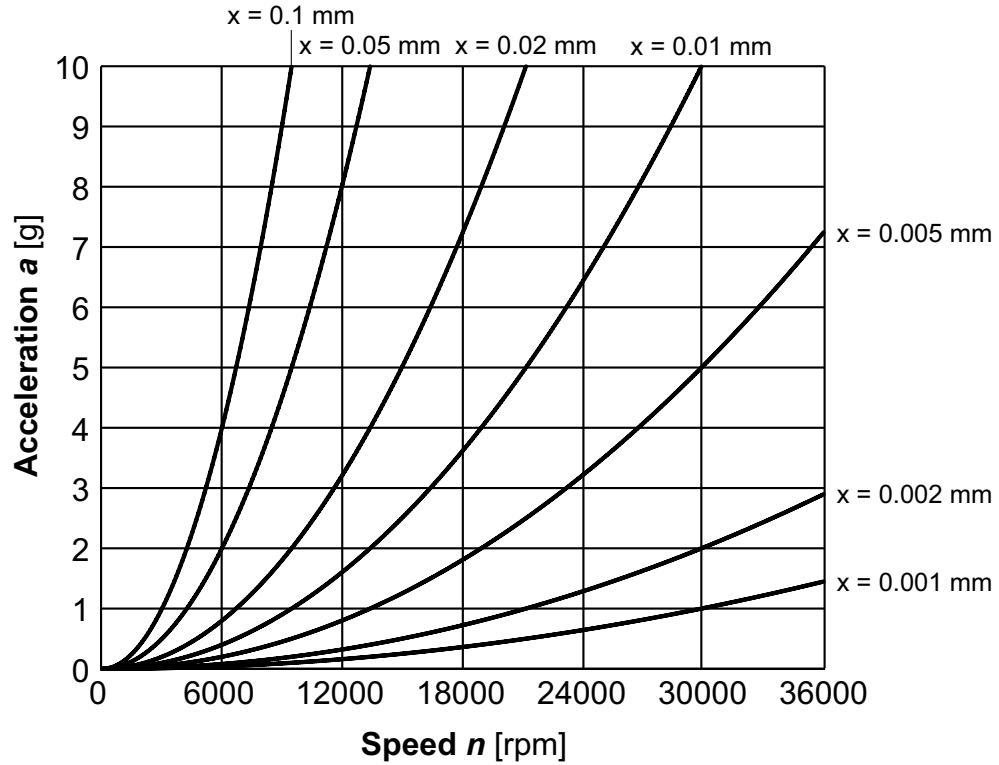

Figure 2-5 Vibratory Acceleration
(as a result of radial displacement and rotational speed)

Magtrol TM Series Torque Transducers have been tested by under the following conditions:

2.3.1.1 Random Vibration

- Power spectral density of 0.05 g^2/Hz between 20 Hz and 500 Hz
- 90 minutes of vibration applied along each of the 3 axes (x, y, z)

2.3.1.2 Sinusoidal Vibration

- Sweep between 10 Hz and 500 Hz at a rate of 1 octave / minute
- From 10 Hz to 60 Hz: 0.35 mm peak-to-peak amplitude
- From 60 Hz to 500 Hz: 5 g peak-to-peak amplitude
- Cycle performed for 90 minutes along each of the 3 axes (x, y, z).



Note: The vibratory level as defined in section 2.3.1.2– *Sinusoidal Vibration* should not be exceeded on a regular basis.

2.3.2 TORQUE SIGNAL CONDITIONING ELECTRONIC CIRCUIT

The TM Series Torque Transducer is fitted with a measuring signal conditioning electronic circuit. This conditioning chain is based on a carrier frequency system containing a synchronous demodulator and a second-order Butterworth-type low-pass filter. The filter's cut-off frequency is adjusted by micro-switches (SW1 to SW12) that are accessible by removing the cover of the transducer's built-in electronics (see *Figure 2-6*). The various setting possibilities are indicated on a label affixed to the back of this cover.

Some applications may warrant fine adjustment of the torque transducer zero point. To activate the offset adjustment potentiometer, simply positioning the SW12 micro-switch to ON. A full-scale zero adjustment of $\pm 10\%$ equivalent to ± 0.5 V can then be carried out by the potentiometer. With the SW12 micro-switch to OFF, the default settings are used.



Note: There are no functions allocated to the SW11 micro-switch.

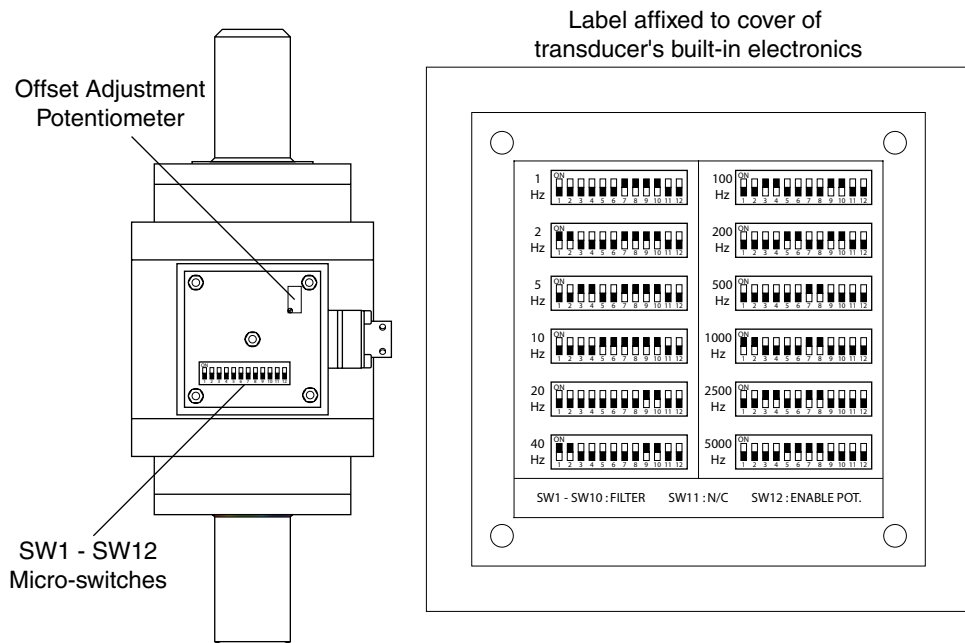

Figure 2-6 SW1 – SW12 Micro-switches and Offset Adjustment Potentiometer

2.4 MOUNTING LIMITS

During static measurements, the nominal torque may be surpassed in order to reach the plastic deformation torque limit. When exceeding the nominal torque, any extraneous loads such as axial, shearing and bending forces must be avoided.

2.4.1 DYNAMIC TORQUE

Static and dynamic measurements differ from one another by the evolution of torque over time. A constant torque produces static measurements, whereas varying torques can only be determined by dynamic measurement.

Magtrol TM Series Torque Transducers are designed for the measurement of both static and dynamic torque, without the need for recalibration.

2.4.2 NATURAL FREQUENCY OF DRIVE TRAIN

In order to determine the dynamic torque and frequency response, and to prevent any damage to the system, it is necessary to calculate the natural frequency of the drive train torsional oscillations. In this system, however, the deformation area of the measuring flange is the weakest link in the rotating measuring chain and is subject to torsional vibrations.

In practice, this situation can generate rather complex relations which require demanding calculations. This may be, for instance, the case for the physical model in which the drive chain is a combination of torsion springs with intermediate flywheel masses. However, the following simplified model of a drive chain (*Figure 2–7*) can often be used.



Note: For a detailed analysis of dynamic response, publications on structural mechanics should be consulted.

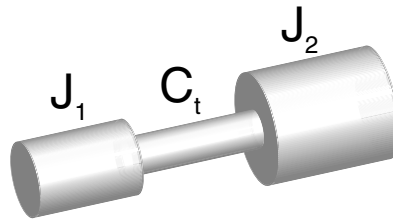

Figure 2–7 Simplified Drive Train Model

$$f_0 = \frac{1}{2\pi} \sqrt{C_t \frac{J_1 + J_2}{J_1 \cdot J_2}}$$

With: f_0 Natural frequency of system [Hz]

C_t Measuring shaft torsional stiffness [Nm/rad]

J_1 Moment of inertia (driving machine + coupling + ½ of the measuring shaft) [kgm²]

J_2 Moment of inertia (driven machine + coupling + ½ of the measuring shaft) [kgm²]



Note: The natural torsional frequency of the drive train is lower due to the presence of the TM Torque Transducer. The system's own natural frequency must then be recalculated to determine the influence of the TM Transducer.

The torsional spring consists only of the deformation zone of the measuring shaft. The torsional stiffness values (C_t) are indicated in the technical data sheets (see *Section 1.3*). J_1 and J_2 are the two moments of inertia acting on each side of the deformation zone. They can be calculated by adding the moments of inertia of each individual element. The moment of inertia of the measuring shaft is also indicated in the data sheet. Consult with the suppliers of the couplings, driving element(s) and driven element(s) in order to obtain the inertia ratings of these drive train components.

The natural torsional frequency (f_0) determines the following:

- the frequency response of the torque measuring system
- whether or not rapid variations in torque can be accurately sensed
- whether or not the torque signal is amplified or attenuated by the dynamics of the drive train

The transfer response is plotted in *Figure 2–8* for various quality factor values (Q), which are dependent upon the amount of damping in the torsional system. The graph charts the factor by which the torque will be amplified, depending on the frequency of the torsional oscillations.

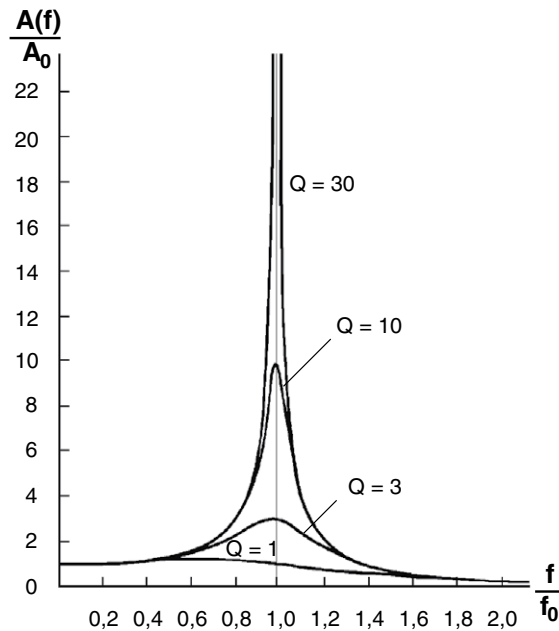

Figure 2–8 Frequency Response Graph



Note: The system should be configured and operated in a manner so that the natural frequency is avoided in everyday operation. The transfer function should be as close to 1 as possible. Consequentially, the frequency of the drive train torsional oscillations should be less than $\sim 0.5 f_0$.

2.4.3 NATURAL MEASURING SHAFT TORSIONAL FREQUENCY

The natural torsional frequency of the measuring shaft corresponds to the frequency at which a torsional resonance may occur. The following table lists the natural frequency of each TM Torque Transducer.

Model	Natural Torsional Frequency
	Hz
TM 301	*
TM 302	171
TM 303	255
TM 304	355
TM 305	476
TM 306	665
TM 307	903
TM 308	1058
TM 309	613
TM 310	879
TM 311	1096
TM 312	1168
TM 312/021	1150
TM 313	1405
TM 313/021	1338
TM 314	1227
TM 314/021	1269
TM 315	1302
TM 315/021	1334
TM 316	1219
TM 317	1212

** These values are not yet available.*



Note: All three versions—TMB, TM and TMHS—of each model are equipped with the same measuring shaft.

2.4.4 MAXIMUM DYNAMIC AMPLITUDE

The dynamic peak-to-peak amplitude must not exceed 200% of the nominal torque of the TM Transducer. This is even true with alternating loads. This amplitude must remain within a range of $-200\% M_{\text{nominal}}$ and $+200\% M_{\text{nominal}}$, as shown in *Figure 2–9*.

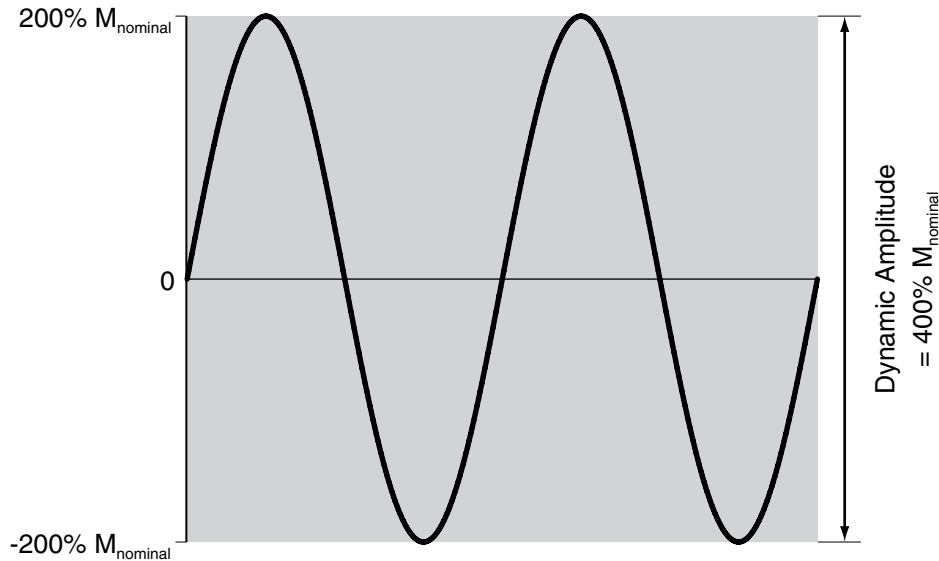

Figure 2–9 Admissible Dynamic Load

2.5 PROTECTIVE SYSTEMS



WARNING! ALL ROTATING PARTS MUST BE FITTED WITH A PROTECTIVE SYSTEM TO ENSURE THAT THE USER, AS WELL AS ALL OTHER SURROUNDING PEOPLE AND OBJECTS, WILL NOT BE INJURED OR DAMAGED AS A RESULT OF THE DRIVE ELEMENT BECOMING BLOCKED, A TORQUE OVERLOAD, OR ANY OTHER POTENTIAL PROBLEM.

The following precautions concerning protective equipment of the drive train must be observed:

- Protective elements must prevent access to moving parts (during test).
- Protective elements must cover all parts which can cause crushing or cutting, and protect against projections of parts having become loose.
- Avoid attaching protective elements to rotating parts.
- Keep protective elements at a sufficient distance away from rotating parts.

Figure 2–10 shows a good example of a protective system. All parts of the bench are accessible, but the covers prevent any risk to the user when closed.

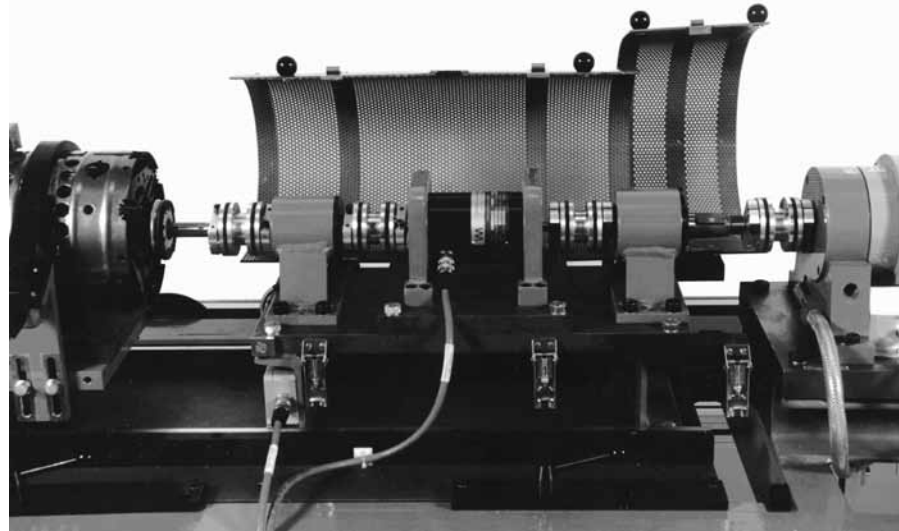

Figure 2-10 Example of Protective System

2.6 ELECTRONIC SIGNAL PROCESSING

Magtrol offers electronic processing units that collect signals from its transducers and displays them on an LCD screen. These units have also been designed for digital processing of the measured values.

2.6.1 MODEL 3410 TORQUE DISPLAY

The Model 3410 Torque Display (formerly Model 3400) processes the torque and speed signals, displays the measured torque and speed values, and displays the calculated power value.



Figure 2–11 Model 3410 Torque Display

With its RS-232 interface, data can be sent to a PC for processing with the LabVIEW™-based Torque 1.0 Software that is supplied with each 3410 Torque Display.

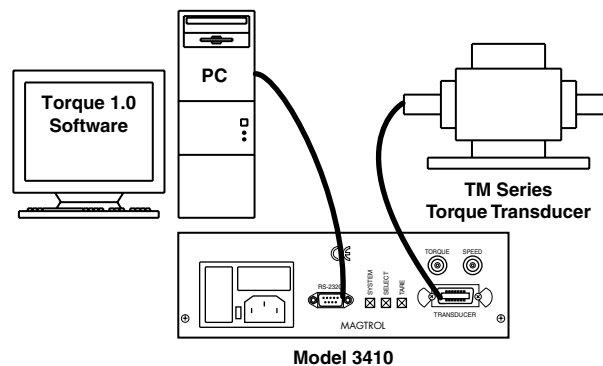

Figure 2–12 PC-Based System Configuration with Model 3410 Display



Note: For additional information regarding the operation of the Model 3410 Display, refer to the corresponding User's Manual (available online at www.magtrol.com).

2.6.2 MODEL 6400 TORQUE TRANSDUCER DISPLAY

This unit has the same characteristics as the Model 3410 Torque Display but with the addition of an analog auxiliary input and fully configurable PASS/FAIL testing capabilities (for conformity tests on the production line).



Figure 2–13 Model 6400 Torque Transducer Display

With either its RS-232 or IEEE-488 interface, data can be sent to a PC for processing with the LabVIEW™-based Torque 1.0 Software (formerly TM Software) that is supplied with each 6400 Torque Display.

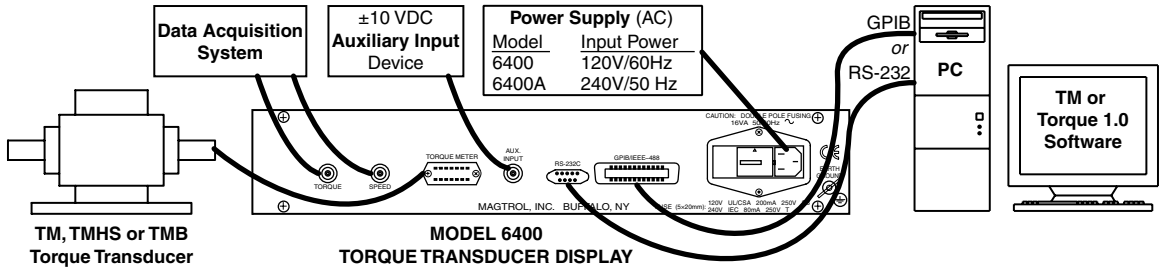

Figure 2–14 PC-Based System Configuration with Model 6400 Display



Note: For additional information regarding the operation of the Model 3410 Display, refer to the corresponding User's Manual (available online at www.magtrol.com).

2.6.3 MODEL DSP6001 PROGRAMMABLE DYNAMOMETER CONTROLLER

Magtrol’s Model DSP6001 Programmable Dynamometer Controller employs state-of-the-art Digital Signal Processing technology to provide superior testing capabilities. The DSP6001 is compatible with all TM Series In-Line Torque Transducers and is also designed to work with any Magtrol HD, WB or PB Dynamometer. Therefore, any Magtrol dynamometer can be used in conjunction with any TM Transducer with both testing devices being controlled by the same unit.

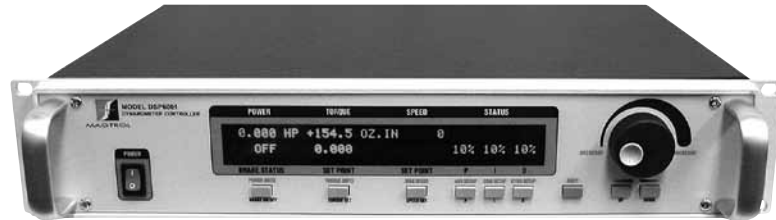

Figure 2–15 Model DSP6001 Programmable Dynamometer Controller

Complete PC control of the test system can be attained via the IEEE-488 or RS-232 interface and Magtrol's M-TEST Software. This LabVIEW™-based program is equipped with ramp, curve and manual testing capabilities to help determine the performance characteristics of a motor under test, and also provides pass/fail testing for production line and inspection applications.

Below is just one example of a system configuration in which both a Magtrol dynamometer and torque transducer are utilized.

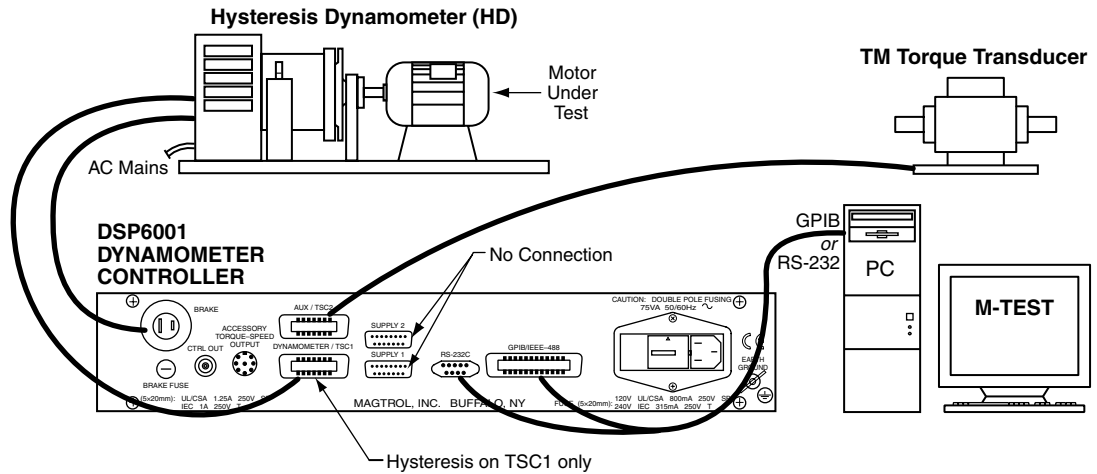

Figure 2–16 PC-Based System Configuration with Model DSP6001 Controller



Note: For more system configuration possibilities, and detailed information regarding the operation of the DSP6001 Controller, refer to the corresponding User's Manual (available online at www.magtrol.com).

2.7 ELECTRICAL CONNECTIONS



Note: The connecting cable assembly (ER 113-0X) consists of a cable with 4 shielded twisted pairs of wires to connect the torque transducer to its signal processing electronic unit. This assembly must be ordered separately.

Connecting the TM In-Line Torque Transducer is extremely simple. Having installed the drive train, only one electrical cable needs to be connected for the system to be operational.

2.7.1 GROUNDING



CAUTION: BEFORE CONNECTING THE TM TORQUE TRANSDUCER TO THE SIGNAL PROCESSING UNIT, THE TRANSDUCER'S HOUSING MUST FIRST BE EARTH-GROUNDED.

The torque transducer, test bench, driving machine and driven machine must be commonly grounded.

With supported torque transducer installations, the support connects the transducer with the test bench grounding. On suspended installations, a special wire needs to be drawn from the transducer's housing to the common ground (as shown in *Figure 2-17*).

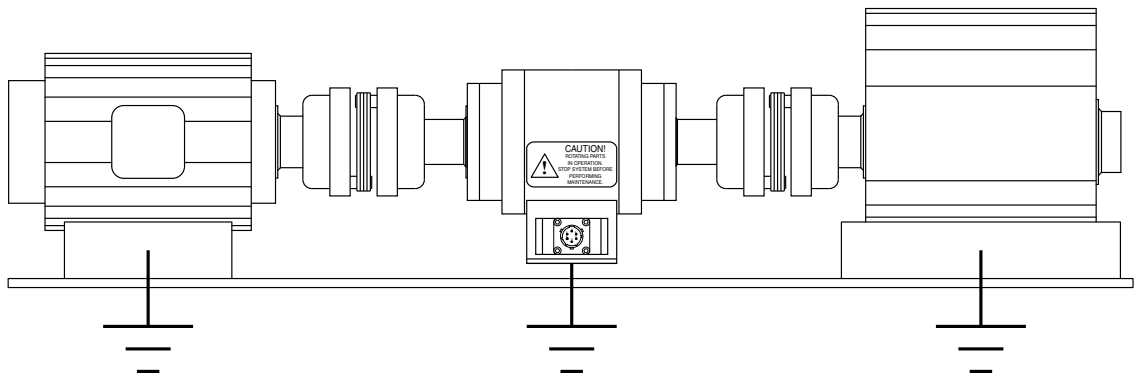
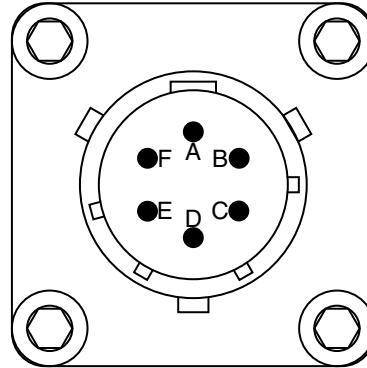

Figure 2-17 Common Grounding

2.7.2 CONNECTING CABLE

The connecting cable to the selected signal processing unit is fitted with a 6-pin Souriau connector on the transducer side and a 14-pin Centronics connector on the side of the signal processing unit. The following signals are transmitted (see *Figures 2–18 and 2–19*) :



- A. Power supply 20 to 32 VDC
- B. Torque signal -10 to +10 VDC
- C. N/C
- D. Power supply/torque grounding 0 VDC
- E. Test signal (high impedance)
- F. Speed signal (open collector)

Figure 2–18 6-pin Souriau Connector Configuration



Note: The test function is only active when the input is grounded.

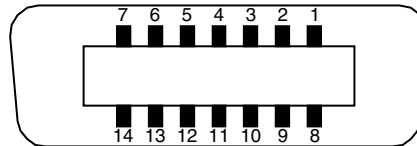

- 1. N/C
- 2. N/C
- 3. Supply +24 VDC
- 4. Power supply grounding 0 VDC
- 5. Shield
- 6. N/C
- 7. N/C
- 8. N/C
- 9. N/C
- 10. Speed signal
- 11. N/C
- 12. Test signal
- 13. Torque signal grounding 0 VDC
- 14. Torque signal -10 to +10 VDC

Figure 2–19 14-pin Centronics Connector Configuration

2.7.3 CONNECTION TO NON-MAGTROL ELECTRONICS

To connect the torque transducer to electronic devices not manufactured by Magtrol, refer to the following connection diagram.

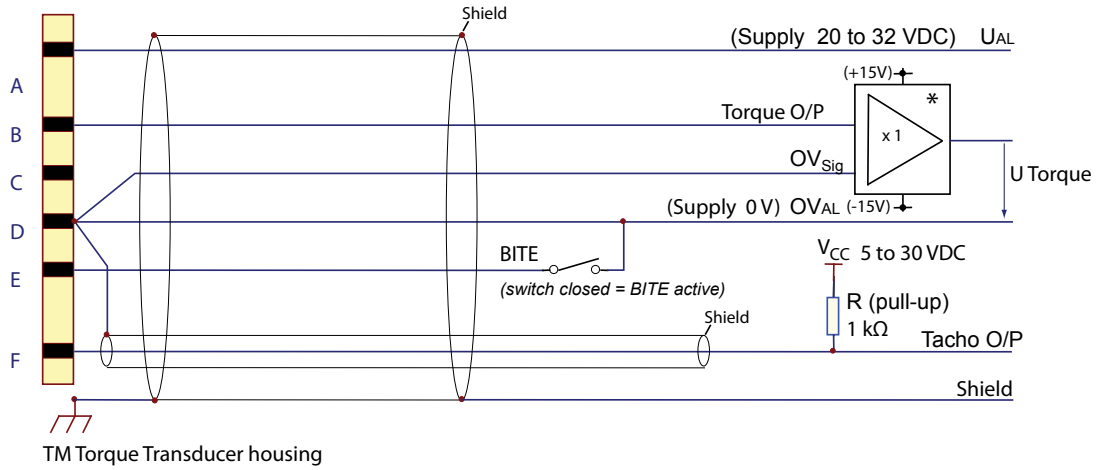

Figure 2–20 Wiring Diagram for Connection to Non-Magtrol Electronics

* A Differential Amplifier is required for elimination of potential DC voltage developing in the 0V leg (OVAL). If there is no Differential Amplifier, a zero shift of the torque signal will occur depending on the resistance and the length of the cable..

2.7.3.1 Pull-up Resistance

A pull-up resistor must be incorporated into the circuit. Pull-up resistance should be set to the following, dependent upon the V_{CC} of the application:

V_{CC}	Pull-up resistance
5 VDC	1 kΩ
20–32 VDC	4.7 kΩ



Note: If the electronics used for speed measurement already has its own internal pull-up resistor, make sure the setting is in accordance with the table above.

2.7.3.2 Tachometer Signal

The tachometer (tacho) signal must be shielded separately. For this purpose, Magtrol recommends using the Model ER 107 Cable Assembly (see Figure 2-21).

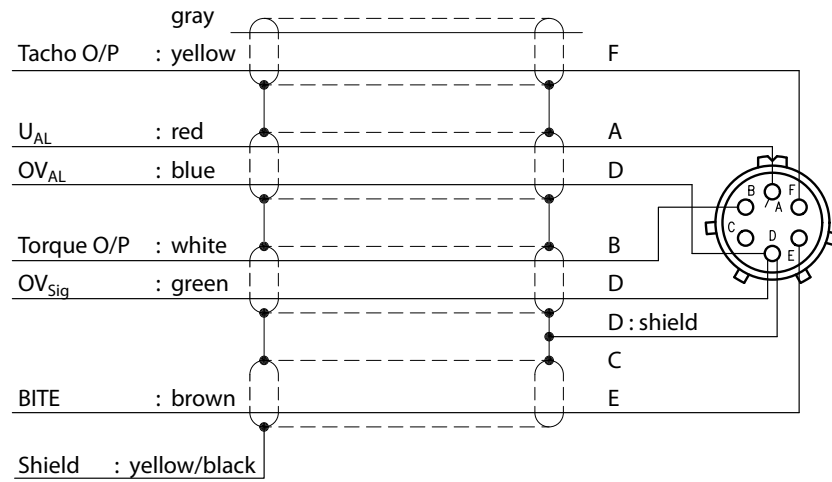

Figure 2-21 ER 107 Pin Configuration

3. Operating Principles

The TM Series In-Line Torque Transducer can be defined as an inductive transducer operating on the basis of a differential voltage transformer having a variable coupling factor.

3.1 TORQUE TRANSDUCER ARCHITECTURE

The part of the transducer effectively measuring the torque is composed of three elements: a shaft with a deformation zone, a pair of coils and two metallic cylinders.

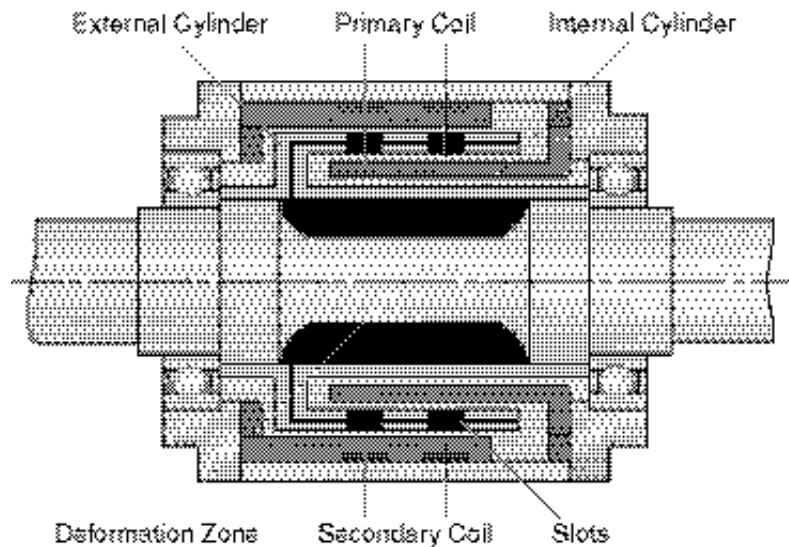

Figure 3-1 TM Torque Transducer Principal Elements

The primary and secondary coil composing the differential transformer are separated by two concentric aluminum cylinders. These cylinders are connected to the torque measuring shaft—the external cylinder on one side of the deformation zone and the internal cylinder on the opposite side. Both cylinders have two series of slots on their surface. When there is no torque being applied to the measuring shaft, the slots in both cylinders fail to overlap. Because the cylinders are non-magnetic, there is total screening and differential induction cannot be generated between the primary and secondary coil.

As torque is applied to the shaft, the deformation zone undergoes increasing angular deformation. As torque is sensed, the overlap between the slots increases creating an opening for the induction flux. The amount of differential induction is proportional to the applied torque. In this way, when the primary coil is excited by a sinusoidal voltage, the secondary coil produces a voltage whose magnitude is dependent on the applied torque.

3.1.1 DIFFERENTIAL TRANSFORMER

The primary coil of the transformer consists of two equal windings mounted in series. It is excited by an alternative current having a frequency of 20 kHz which is generated by the transducer's built-in electronics. In addition, a constant current is supplied to the primary coil in order to determine the temperature of the entire measuring unit and to compensate the temperature signal.

The secondary coil consists of two windings in phase opposition. This determines the spacing between the cylinder slots and produces a torque-proportional dynamic voltage signal.

3.2 SPEED CONDITIONING CHAIN

A speed transducer is incorporated into the torque transducer housing in order to measure the rotational speed of the measuring shaft. This optical transducer is mounted facing a toothed part of the rotor and produces 60 pulses per revolution.

3.3 BUILT-IN SELF-TEST CIRCUIT

The torque transducer's connector has a pin allocated for activating a test signal. When this pin is held low (logic 0), a test signal equivalent to +5 V DC is activated which superimposes itself to the torque measuring signal. Therefore, this self-test may be carried out while the transducer is in use. The signal is supplied by the control electronics.

The self-test circuit checks the correct functioning of the torque signal conditioning unit. This function, however, does not in any way obviate the need for a static calibration of the transducer.

4. Maintenance / Repair

4.1 MAINTENANCE

Magtrol TM Series In-Line Torque Transducers are virtually maintenance-free. This is due to the following aspects of their construction:

- Lifelong lubrication of the bearings.
- Transmission of the torque signal from the rotating measuring elements to the signal processing electronics by a process of induction rather than by using slip rings. This eliminates mechanical wear.

However, it may be necessary to change the bearings after extended use. The theoretical lifetime of the bearings is 5000 hours and Magtrol recommends that the bearings be replaced after this time. (Bearings should be replaced as soon as they start showing signs of wear.) Higher wear occurs when the transducer is operated outside its optimal working conditions. This is especially true when the transducer is operated at excessive rotational speeds, which results in the generation of axial and radial forces on the bearings.



CAUTION : THE USER SHOULD NOT ATTEMPT TO CHANGE THE BEARINGS HIMSELF. THE TRANSDUCER SHOULD BE RETURNED TO MAGTROL FOR THIS OPERATION. SIMILARLY, THE USER SHOULD NOT ATTEMPT TO CARRY OUT REVISIONS OR REPAIRS OF ANY KIND ON THE MECHANICAL OR ELECTRONIC COMPONENTS MAKING UP THE TRANSDUCER. IF A PROBLEM IS SUSPECTED, MAGTROL SHOULD BE CONTACTED SO THAT ARRANGEMENTS CAN BE MADE TO PERFORM ANY REPAIRS IN THE FACTORY. FAILURE TO OBSERVE THE ABOVE MAY LEAD TO THE TRANSDUCER BEING SERIOUSLY DAMAGED.



Note: The TM Transducer housing is sealed. If there is any evidence that the housing has been opened and unauthorized modifications have been attempted, the warranty will be invalidated.

4.2 REPAIR

In case of a defect, please refer to both the *Warranty* and *Service Information* located at the back of this manual. Whether you are directed to ship your equipment back to Magtrol, Inc. in the United States or Magtrol SA in Switzerland, it is very important to include the following information with your return shipment:

- Model number, part number, serial number, order number and date of acquisition
- Description of the defect and the conditions in which it appeared
- Description of the test bench (drawing, photographs, sketches, etc.)
- Description of the tested object (drawing, photographs, sketches, etc.)
- Description of the test cycle



CAUTION: MAINTENANCE MUST BE PERFORMED BY MAGTROL IN ORDER TO GUARANTEE
FUTURE MEASURING ACCURACY.

To allow Magtrol to complete the work in the best possible time, carefully pack the torque transducer and follow the procedure outlined in the rear of this manual under *Service Information*.

Service Information

RETURNING MAGTROL EQUIPMENT FOR REPAIR AND/OR CALIBRATION

Before returning equipment to Magtrol for repair and/or calibration, please visit Magtrol's Web site at <http://www.magtrol.com/support/rma.htm> to begin the Return Material Authorization (RMA) process. Depending on where the equipment is located and which unit(s) will be returned, you will be directed to either ship your equipment back to Magtrol, Inc. in the United States or Magtrol SA in Switzerland.

Returning Equipment to Magtrol, Inc. (United States)

When returning equipment to Magtrol, Inc.'s factory in the United States for repair and/or calibration, a completed Return Material Authorization (RMA) form is required.

1. Visit Magtrol's Web site at <http://www.magtrol.com/support/rma.htm> to begin the RMA process.
2. Complete the RMA form online and submit.
3. An RMA number will be issued to you via e-mail. Include this number on all return documentation.
4. Ship your equipment to:
MAGTROL, INC.
70 Gardenville Parkway
Buffalo, NY 14224
Attn: Repair Department
5. After Magtrol's Repair Department receives and analyzes your equipment, a quotation listing all the necessary parts and labor costs, if any, will be faxed or e-mailed to you.
6. After receiving your repair estimate, provide Magtrol with a P.O. number as soon as possible. A purchase order confirming the cost quoted is required before your equipment can be returned.

Returning Equipment to Magtrol SA (Switzerland)

If you are directed to ship your equipment to Switzerland, no RMA form/number is required. Just send your equipment directly to Magtrol SA in Switzerland and follow these shipment instructions:

1. Ship your equipment to:
MAGTROL SA
After Sales Service
Centre technologique Montena
1728 Rossens / Fribourg
Switzerland
VAT No: 485 572
2. Please use our forwarder : TNT • 1-800-558-5555 • Account No 154033
Only ship ECONOMIC way (3 days max. within Europe)
3. Include the following documents with your equipment:
 - Delivery note with Magtrol SA's address (as listed above)
 - Three pro forma invoices with:
 - Your VAT number
 - Description of returned goods
 - Noticed failures
 - Value - for customs purposes only
 - Origin of the goods (in general, Switzerland)
4. A cost estimate for repair will be sent to you as soon as the goods have been analyzed. If the repair charges do not exceed 25% the price of a new unit, the repair or calibration will be completed without requiring prior customer authorization.



Testing, Measurement and Control of Torque-Speed-Power • Load-Force-Weight • Tension • Displacement

www.magtrol.com

MAGTROL INC

70 Gardenville Parkway
Buffalo, New York 14224 USA
Phone: +1 716 668 5555
Fax: +1 716 668 8705
E-mail: magtrol@magtrol.com

MAGTROL SA

Route de Montena 77
1728 Rossens/Fribourg, Switzerland
Phone: +41 (0)26 407 3000
Fax: +41 (0)26 407 3001
E-mail: magtrol@magtrol.ch

Subsidiaries in:

Germany • France
China • India

Worldwide Network
of Sales Agents

