

M-TEST 5.0 Motor Testing Software

NEW FEATURES WITH M-TEST 5.0

- **New Graphical User Interface:** Tabbed pages for quick navigation.
- **Temperature/Sensor Measurement:** Temperature testing capabilities are now included in standard program.
- **Multiple Language Support:** Switch to/from English, French, German or Spanish at any point during the program. Additional language dictionaries can be created/edited by the user.
- **More Graphing Options:** Display up to three different 1-axis graphs (one for each tested parameter) in the same window.
- **Compare Test Data:** Overlay data from two separate tests on the same graph.
- **Rapid Graph Plotting:** Change both the X- and Y-axis to display additional test curves, without having to exit the graph.
- **Cursor Tools:** Obtain the X and Y coordinates of any point on a curve. Magnify any section of the graph.
- **Simplified PID Scaling:** New slider controls set both coarse and fine gain adjustment simultaneously.
- **Single or Multi-User Login:** Enable password protection and assign user access rights for specific program functions.
- **Loads Most Recently Saved Setup File Upon Startup:** Provides valuable time savings for users who repeatedly run only one type of test.
- **Automatic GPIB Device/Address Detection:** Displayed within program to easily check communication parameters.



M-TEST 5.0 Hardware Configuration



M-TEST 5.0 Graphical Data Output

DESCRIPTION

Magtrol's new M-TEST 5.0 is a state-of-the-art motor testing program for PC (Windows® 2000/XP) based data acquisition. Used with a Magtrol Programmable Dynamometer Controller, M-TEST 5.0 works with any Magtrol Dynamometer or In-Line Torque Transducer to help determine the performance characteristics of a motor under test. Up to 22 parameters are calculated and displayed utilizing M-TEST 5.0's feature-rich testing and graphing capabilities.

An integral component of any Magtrol Motor Test System, M-TEST 5.0 performs ramp, curve, manual and pass/fail tests in a manner best suited to the overall efficiency of the test rig. Written in LabVIEW™, M-TEST 5.0 has the flexibility to test a variety of motors in a multitude of configurations. The data generated from this user-friendly program can be stored, displayed and printed in tabular or graphical formats, and is easily imported into a spreadsheet.

Magtrol can also make custom modifications to the software to meet additional motor testing requirements.

SENSOR INPUT MEASUREMENT

Temperature measurement—previously an add-on feature that had to be purchased separately—is now included in M-TEST 5.0. Up to 32 thermocouples or analog sensors can be read and monitored during a motor test. Heat rise curves on the bearings, windings and housing of a motor can be performed and air flow/exhaust efficiencies can be measured with an air tool or internal combustion engine. M-TEST 5.0, with its complete dynamometer control, even allows for sensor measurement while performing load simulation for duty cycle and life testing.

APPLICATIONS

M-TEST 5.0—besides being well-suited for simulating loads, cycling the unit under test and motor ramping—is also ideal for production line and inspection applications, due to its pass/fail test function. Another time-saving feature, that engineering labs will benefit from, is the ability to duplicate tests and run them automatically. This versatile program is extremely valuable to anyone involved in motor testing.

STANDARD FEATURES

- **Multiple Testing Options:**
 - Ramp: Select from average ramp down/up or ramp down with inertia correction factor. Also allows extrapolation of free-run and locked-rotor data, plus interpolation of specific speed or torque data points.
 - Curve: Test speed, torque, amps, watts input, watts output and open loop parameters. Capable of adjusting sampling rate and using step or ramp from one load point to the next.
 - Manual: Runs test from front panel of the Dynamometer Controller while computer acquires data. Allows adjustment of sampling rate.
 - Pass/Fail: Checks amps, input watts (with optional Power Analyzer), speed, torque and output watts against user-defined values.
- **Displays 22 Tested and Calculated Parameters:** Torque, speed and auxiliary input are displayed from the DSP6000/6001, 5240 or 4629B Controller; amps, volts and watts from an (optional) power analyzer. Calculated values including horsepower, efficiency, power factor, output watts and time can also be displayed.
- **Three-Phase Power Analyzer Data Acquisition:** Obtain data on each individual phase and/or the sum used in the chosen parameters (amps, volts, input watts and power factor).
- **Motor Shaft Direction Indicator:** Indicates if the motor is turning clockwise or counterclockwise.
- **IEEE-488 and RS-232 Interface:** Computer interface with National Instruments™ PCI-GPIB. RS-232 available with DSP6001 and DSP6000 only.
- **Automatic Load Defaults Option:** Downloads testing instrument parameters based on model number.
- **Dynamic PID Scaling:** Provides consistent control loop results throughout motor speed range during ramp test (for DSP6001 only).
- **PID Adjustment Routines:** Helps adjust the system for ramp and step functions.
- **Graphing Capabilities:** Display up to 5 test curves in a single graph or view as (up to 3) separate 1-axis graphs; easy-to-read colored and labeled plots with several graph formatting options; manual or auto scaling.
- **Curve Fitting:** A curve fitting routine can be applied to most motor test curves. Raw data and curve fit data can also be displayed simultaneously.
- **Customized Reports:** Allows user to produce a one-page motor test summary, which can include the motor's serial number; maximum torque, speed, power and current values; operator name; time and date of test; motor direction; 32 data points; and an X-Y plot.
- **Save/Load Setup Function:** Test procedure configurations may be stored and recalled using standard Windows® file structure.

SYSTEM CONFIGURATION

A Magtrol Dynamometer provides motor loading with a Magtrol Programmable Dynamometer Controller acting as the interface between the PC running M-TEST 5.0 and the dynamometer. If motor electrical parameters are to be measured or used to determine load points, a Magtrol Power Analyzer is also required. Interfacing between the computer and electronic instrumentation is via the National Instruments™ PCI-GPIB card or RS-232 serial interface (when using a DSP6000 or DSP6001).

M-TEST 5.0 is equipped to work in conjunction with any of the following Magtrol motor testing instruments:

- Dynamometer Controller (DSP6001/6000, 5240, 4629B)
- Hysteresis, Eddy-Current or Powder Dynamometer (HD, WB, PB)
- In-Line Torque Transducer (TM, TMB, TMHS)
- Power Analyzer (6530, 6510e, 6510, 6550, 5100, 5300)

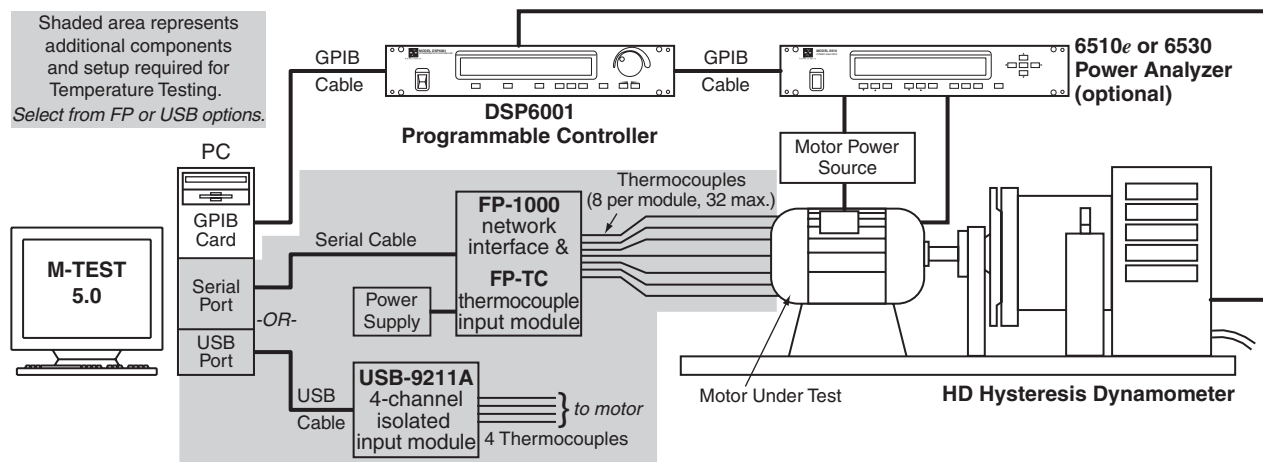

SYSTEM REQUIREMENTS

- Personal computer with Intel® Pentium® IV processor (or equivalent)
- Microsoft® Windows® 2000/XP
- 1 GB of RAM
- 1.6 GB of available hard drive space
- VGA color monitor with minimum screen resolution of 1024 × 768
- National Instruments™ PCI-GPIB card (available from Magtrol)
- RS-232 serial interface can be used, instead of GPIB card, for interfacing with Magtrol DSP6000 or DSP6001 Controllers
- National Instruments™ FieldPoint™ or USB-9211A hardware: Required only if temperature testing/sensor input function will be used

SYSTEM OPTIONS AND ACCESSORIES

CATEGORY	DESCRIPTION	MODEL / PART #
TEMPERATURE TESTING HARDWARE	FieldPoint 8-Channel Isolated Input Module (FP-TC-120-X), Network Interface (FP-1000), 120 V Power Supply and Serial Cable	HW-TTEST-FP
	FieldPoint 8-Channel Isolated Input Module (FP-TC-120-X), Network Interface (FP-1000), 240 V Power Supply and Serial Cable	HW-TTEST-FP-A
	Additional FieldPoint 8-Channel Thermocouple Module (includes mounting base)	004968
	USB 4-Channel Isolated Input Module (USB-9211A) and USB Cable (1 m)	HW-TTEST-USB
CONTROLLERS	High Speed Programmable Dynamometer Controller	DSP6001
TESTING INSTRUMENTS	Hysteresis Dynamometers	HD series
	Eddy-Current Dynamometers	WB series
	Powder Brake Dynamometers	PB series
	In-Line Torque Transducers	TM/TMHS/TMB series
POWER ANALYZERS	High Speed Single-Phase Power Analyzer	6510 _e
	High Speed Three-Phase Power Analyzer	6530
POWER SUPPLIES	Closed-Loop Speed Control and Power Supply	6100
	Power Supply for WB & PB Dynamometers series 2.7 and 43	DES 310
	Power Supply for WB & PB Dynamometer series 65, 115 and 15	DES 311
	Power Amplifier—required for all HD-825 Dynamometers	5241
MISC	Torque/Speed Conditioner	TSC 401
CARDS	GPIB Interface Card (PCI)	73-M023
	Relay Actuator Card (for controlling motor power via M-TEST 5.0)	73-M052
CABLES	GPIB Cable, 1 meter	88M047
	GPIB Cable, 2 meters	88M048
	Torque Transducer Connector Cable	ER 113/01

For information on the most current software release available, refer to Magtrol's Web site at www.magtrol.com/motortest/mtest.htm

Due to the continual development of our products, we reserve the right to modify specifications without forewarning.



www.magtrol.com

MAGTROL INC

70 Gardenville Parkway
Buffalo, New York 14224 USA
Phone: +1 716 668 5555
Fax: +1 716 668 8705
E-mail: magtrol@magtrol.com

MAGTROL SA

Route de Montena 77
1728 Rossens/Fribourg, Switzerland
Phone: +41 (0)26 407 3000
Fax: +41 (0)26 407 3001
E-mail: magtrol@magtrol.ch

Subsidiaries in:

Great Britain
Germany • France
China • India
Worldwide Network
of Sales Agents

