Micro Dyne Motor Testing System

FEATURES

- DESIGNED SPECIFICALLY for miniature and micro motors
- Torque: Easily convertible from 2.0 mN·m to 4.0 mN·m (0.28 oz·in to 0.57 oz·in)
- Speed: up to 100,000 rpm
- Power: 4 W
- Low inertia
- Sold as a complete, out-of-the-box motor testing system. Components include:
 - Hysteresis Dynamometer: provides precise torque loading independent of shaft speed
 - Motor Fixture: accommodates motors from 5 mm to 30 mm in diameter.
 - Dedicated Electronics: all-in-one dynamometer controller, DC wattmeter, power relay and USB interface
 - Comprehensive Motor Testing Software
 - Easy-to-use calibration software
 - All necessary connection cables
 - Calibration weights: 5 g and 10 g



APPLICATIONS

Magtrol motor test systems can be found in test labs, at inspection stations, and on the manufacturing floors of most of the world's leading motor manufacturers. The Micro Dyne system is used exclusively for closed-loop testing of miniature motors and micro motors used in low-torque/high-speed applications.

Motor sub-types include, but are not limited to, the following:

- Brushed and brushless DC motors
- Gearmotors
- Brushless DC servomotors
- Vibrator motors
- Miniature air motors

These mini/micro motors are used in a diverse range of industries and products, including:

- Medical and laboratory equipment
- Robotics and automation
- Toys
- Handheld communication devices
- Audio/video equipment
- Optics and photonics
- Aerospace and defense
- Security and instrumentation
- Industrial machinery

DESCRIPTION

With over 50 years' experience in dynamometer design and torque measurement, Magtrol has revolutionized the industry. Magtrol's NEW Micro Dyne, capable of measuring extremely low torques (2.0 mN·m can be resolved to 0.0004 mN·m), is designed EXCLUSIVELY for testing miniature and micro (low-torque) motors.

Motor Characteristics Measured/ Calculated:

- Torque
- Speed
- Amps
- Volts
- Horsepower
- Efficiency
- Input Watts
- Output Watts

For the utmost convenience, the Micro Dyne is packaged as a COMPLETE MOTOR TESTING SYSTEM. Everything that is needed to accurately and efficiently test miniature motors and micro motors is included with the purchase of a Magtrol Micro Dyne. The only component that needs to be supplied by the customer is a laptop or desktop personal computer and motor power supply.

SYSTEM MODEL

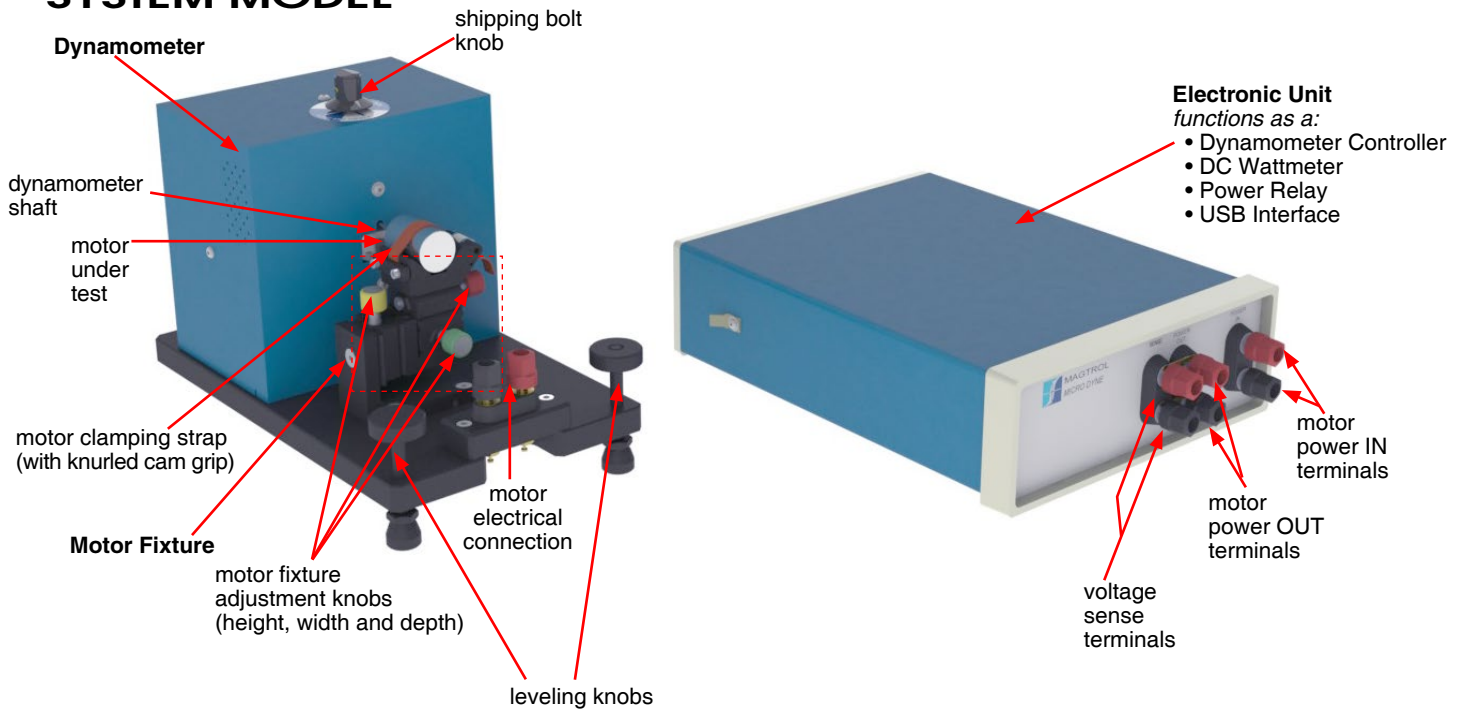

BLOCK DIAGRAM

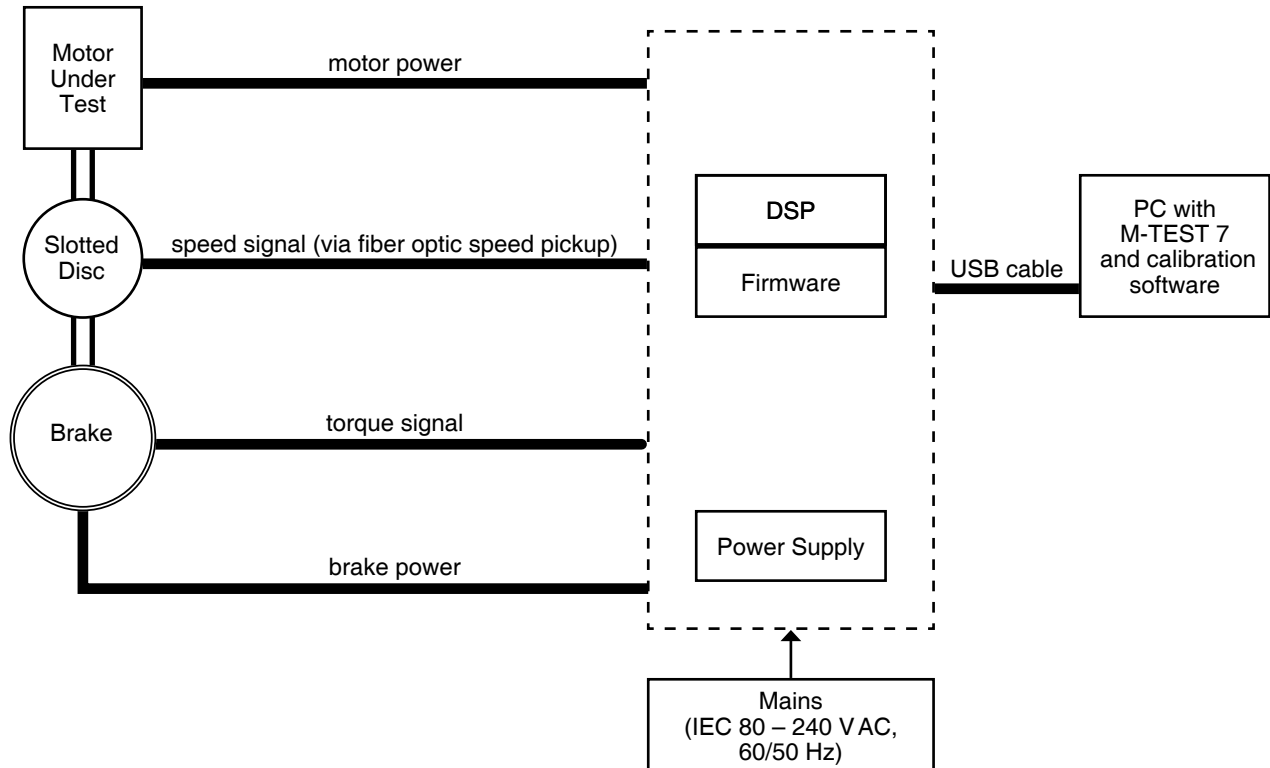

SYSTEM COMPONENTS

Dynamometer



The Micro Dyne dynamometer absorbs power with Magtrol's unique Hysteresis Braking System. Because it does not require speed to create torque, the dynamometer can conduct a full motor ramp—from free-run to locked rotor.

In addition to a dedicated motor fixture, the dynamometer base plate also includes leveling knobs and motor power terminals. The housing of the dynamometer protects all the moving parts of the brake.

Electronic Unit



At the hub of the Micro Dyne system is a multifunctional electronic unit. The unit employs DSP technology for high-speed data acquisition and complete PC

control of the dynamometer. A USB receptacle enables easy connection to a personal computer. An integrated DC wattmeter reads volts and amps, and calculates watts; and a built-in power relay controls motor power (on/off).

The front panel includes the terminals for motor power in/out and voltage sensing. LED power and communication indicators are located on the rear panel of the unit.

Motor Fixture



Attached to the dynamometer base plate is a motor fixture designed expressly for micro/miniature motors. The base of the fixture features an XYZ stage with 3-axis positioning for excellent adjustability and motor centering. With the included adapters, motors from 5 mm to 30 mm in diameter can be easily mounted. The fixture is keyed to help secure the motor under test and a rubber strap with knurled cam grip provides motor clamping.

Motor Testing Software



Magtrol's M-TEST 7 is a state-of-the-art comprehensive motor testing program designed for use with Windows® operating systems for PC-based data acquisition. The software measures and calculates a motor's performance

characteristics by employing these user-configurable testing methods:

- Ramp:** Select from average ramp down/up or ramp down with inertia correction factor. Also allows extrapolation of free-run and locked-rotor data, plus interpolation of specific speed or torque data points.
- Curve:** Test speed, torque, amps, watts input, watts output and open loop parameters, and compares actual values to user-defined limits. Capable of adjusting sampling rate and using step or ramp from one load point to the next.
- Pass/Fail:** Checks amps, input watts, speed, torque and output watts against user-defined values.

The data generated can then be stored, displayed and printed in tabular or graphic formats, and is easily imported into a spreadsheet.

OPERATING PRINCIPLES

Speed Measurement

The Micro Dyne contains a reflective fiber optic speed pickup. Each rotor slot that passes by the sensing end of the fiber optic generates an electronic pulse, which is then converted to a speed reading (in rpm).

Torque Measurement

A hysteresis brake is used to develop a resistance to rotation of a mechanical shaft. A torsional force is produced by the test motor and applied to the brake's rotor-shaft assembly. Reaction torque is measured by the angle of the brake pendulum assembly and is interpreted by the Micro Dyne system software (M-TEST 7).

DYNAMOMETER

The Micro Dyne offers two different torque configurations in one unit. Depending on the motor's maximum torque rating, the user can easily switch between the 2.0 mN·m and 4.0 mN·m torque settings via the dynamometer's rear access panel. The ratings are the same for either configuration.

| Maximum Torque | Nominal Input Inertia | Maximum Kinetic Power | | Maximum Speed * | Accuracy | |
|-------------------|--------------------------|-----------------------|--------------|-----------------|--------------------|--------------------|
| | | 5 minute | continuous** | | Torque | Speed |
| <i>mN·m</i> | <i>kg·cm²</i> | <i>W</i> | <i>W</i> | <i>rpm</i> | < 1% of full scale | < 0.02% of reading |
| 4.0 or 2.0 | 5.43×10^{-4} | 4 | 4 | 100,000 | | |

* Because the MicroDyne is optimized for high speeds, the lowest measurable speed is 50 rpm. If a motor is operating at less than 50 rpm, the speed measurement will read zero.

** NOTE: Operating at the continuous power rating for periods of up to 4 hours is acceptable. However, operating for extended periods at high temperatures will result in premature component and bearing failure. Limiting the length of the cycle and the component temperatures will guard against premature failure. Where continuous duty is desired for longer time intervals, component temperatures should be maintained less than 100°C; monitoring the outside brake surface temperature is a sufficient reference.

Power Absorption Curve

Based on the maximum kinetic power ratings, the curve below represents the maximum power (heat) that the dynamometer can dissipate over time. The area under the curve equals the maximum speed/torque combinations for both a motor test of less than 5 minutes (intermittent duty), and a continuous-duty motor test.

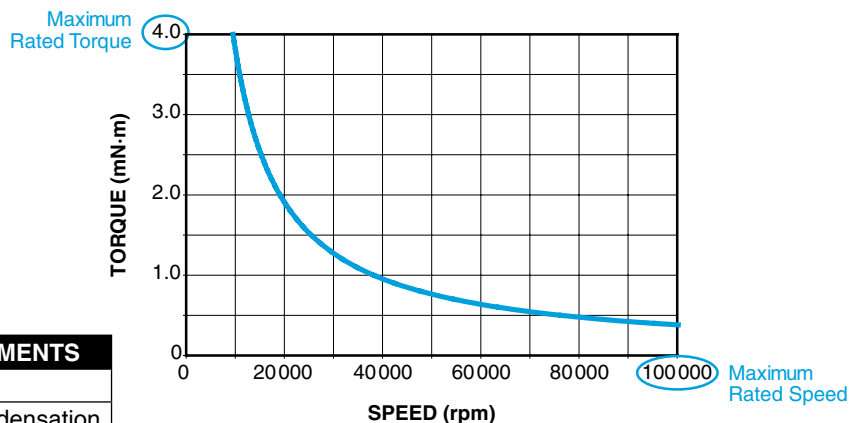

| DYNAMOMETER ENVIRONMENTAL REQUIREMENTS | |
|--|-----------------------------------|
| Operating Temperature | 0 °C to +70 °C |
| Relative Humidity | < 60% without condensation |
| EMC | In accordance with IEC 61326:2002 |

ELECTRONIC UNIT

| GENERAL ELECTRICAL CHARACTERISTICS | |
|------------------------------------|----------------------------|
| Fuse (5 × 20 mm) | IEC 315 mA 250 V T |
| Power Requirements | 14 VA |
| Voltage Requirements | 85 – 264 VAC, 60/50 Hz |
| ENVIRONMENT | |
| Operating Temperature | 0 °C to +70 °C |
| Relative Humidity | < 60% without condensation |

| POWER MEASUREMENT (DC) | |
|-------------------------------|---------------------------------------|
| Current Input (isolated) | ± 5 A ±(0.1% Reading + 0.2% Range) |
| Voltage Input (isolated) | ± 30 VDC ±(0.1% Reading + 0.2% Range) |
| Conversion Rate | 15/second |
| Power Accuracy | 0.4% of VA range |
| Isolation, to earth | 50 VDC |
| Isolation, channel-to-channel | 100 VDC |

MOTOR FIXTURE

| MOTOR ACCOMMODATION | |
|----------------------|----------------|
| Motor Diameter | 5 mm – 30 mm |
| Motor Length | 5 mm – 50 mm |
| Motor Shaft Diameter | 0.75 mm – 3 mm |
| Maximum Load | 100 g |

| ADJUSTABILITY | |
|----------------------------|------------------|
| X/Y/Z Adjustable Range | ±5 mm (all axes) |
| Controllable Motion | 0.005 mm |
| Travel per Knob Revolution | 0.318 mm |

DYNAMOMETER

Weight 4.2 kg 9.3 lb

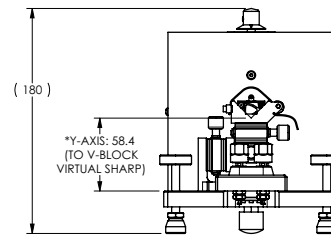
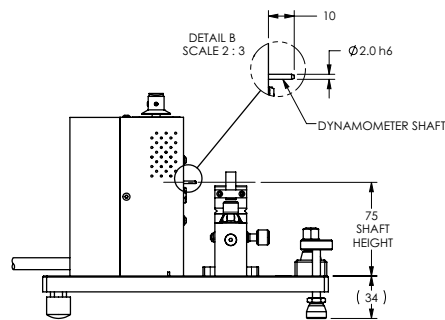
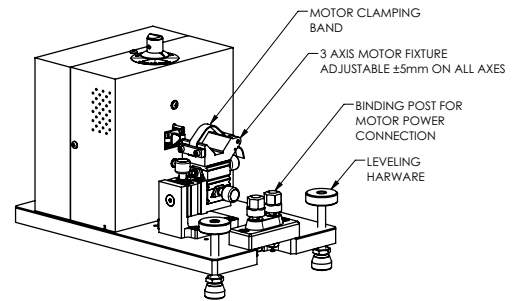
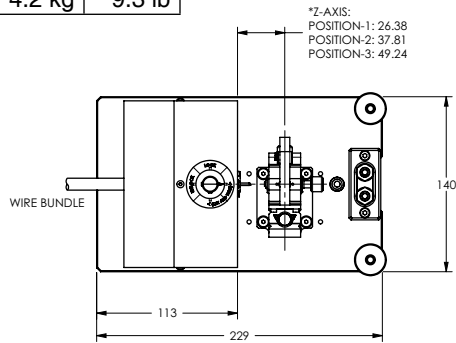

ELECTRONIC UNIT

Weight 1.5 kg 3.2 lb

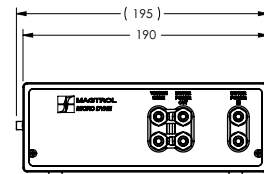
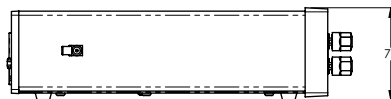
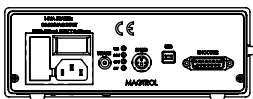
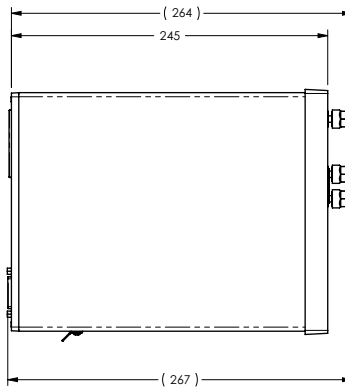

Due to the continual development of our products, we reserve the right to modify specifications without forewarning.



www.magtrol.com

MAGTROL INC

70 Gardenville Parkway
Buffalo, New York 14224 USA
Phone: +1 716 668 5555
Fax: +1 716 668 8705
E-mail: magtrol@magtrol.com

MAGTROL SA

Route de Montena 77
1728 Rossens/Fribourg, Switzerland
Phone: +41 (0)26 407 3000
Fax: +41 (0)26 407 3001
E-mail: magtrol@magtrol.ch

Subsidiaries in:

Germany • France
China • India
Worldwide Network
of Sales Agents

