

---

# KG-05

## Extensometer

---

### FEATURES

- Strain transducer, impedance 1000  $\Omega$
- Temperature-compensated
- IP 66 protection class
- Compact dimensions
- Robust design
- Very flat construction
- Easy mounting on machined flat surface
- Maintenance-free

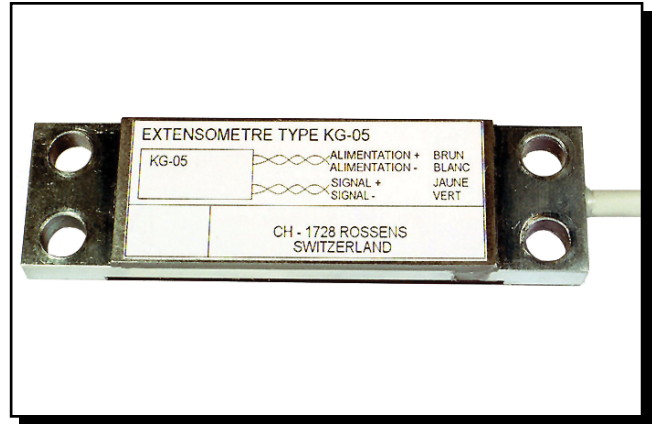

### DESCRIPTION

The Magtrol KG-05 Extensometer is designed for measuring deformations of construction or machined parts under load. Because its output signal is proportional to the applied load, it can be used as either a load cell or a force transducer.

### APPLICATIONS

The KG-05 Extensometer is ideal for strain measuring where large transducers are not suitable. Its small dimensions and flat mounting allow for easy control of deformations on steel structures.

### SYSTEM CONFIGURATION OPTIONS

---

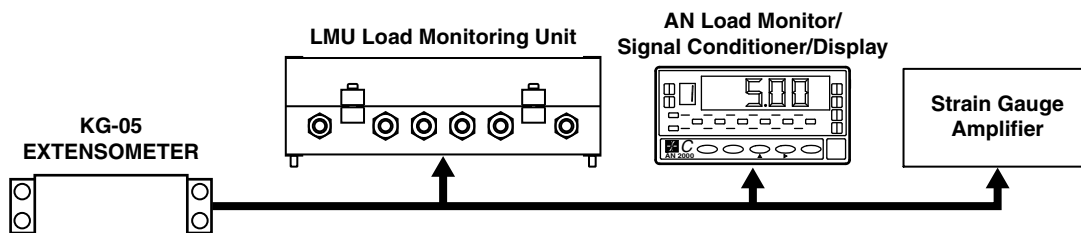

**TECHNICAL RATINGS**

<b>MECHANICAL CHARACTERISTICS</b>	
Maximal Usable Load	1.5 × nominal load
<b>ELECTRICAL CHARACTERISTICS</b>	
Nominal Traction and Compression Deformation ( $\epsilon$ )	$\pm 600 \cdot 10^{-6}$
• Dynamic (long-term)	Double amplitude $\leq 400 \cdot 10^{-6}$ within static limits
Nominal Sensitivity (at $\epsilon = 600 \cdot 10^{-6}$ )	1.5 mV/V *
Input Impedance	990 $\Omega$ to 1200 $\Omega$
Output Impedance	1000 $\pm 10 \Omega$
<b>ENVIRONMENTAL CHARACTERISTICS</b>	
Temperature Compensation	For steel with $\alpha = 11 \cdot 10^{-6}$ as standard **
Compensated Temperature	-10 °C to +40 °C
Operating Temperature	-30 °C to +70 °C
Protection Class	IP 66
<b>CONNECTION CABLE</b>	
Shielded Cable Length	3 m (Other cable lengths available upon request.)
Pin Connections:	Color Code (according to DIN):
supply (+)	brown
supply (-)	white
signal (+)	yellow
signal (-)	green

\* Units calibrated with tolerance of  $\pm 2\%$  upon request.      \*\* Adaptable for other metals upon request.

**DIMENSIONS**

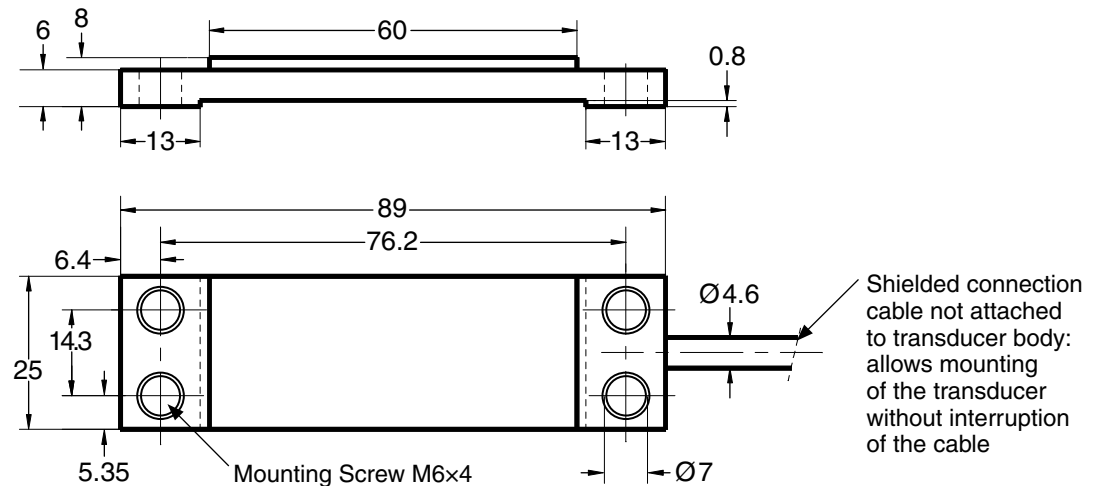

*Due to the continual development of our products, we reserve the right to modify specifications without forewarning.*



[www.magtrol.com](http://www.magtrol.com)

**MAGTROL INC**  
 70 Gardenville Parkway  
 Buffalo, New York 14224 USA  
 Phone: +1 716 668 5555  
 Fax: +1 716 668 8705  
 E-mail: magtrol@magtrol.com

**MAGTROL SA**  
 Centre technologique Montena  
 1728 Rossens/Fribourg, Switzerland  
 Phone: +41 (0)26 407 3000  
 Fax: +41 (0)26 407 3001  
 E-mail: magtrol@magtrol.ch

**Subsidiaries in:**  
 Great Britain  
 Germany • France  
 China • India  
 Worldwide Network  
 of Sales Agents

