

AMF Series

Adjustable Motor Fixtures

FEATURES

- Accommodate motors up to 8¼ inches in diameter
- Used with most Magtrol HD Series Dynamometers
- Secure anchoring system
- Easy motor centering
- Extremely versatile and adaptable
- Vibration protection
- Scratch-free clamping
- Tool-free adjustment
- Direct mounting to Magtrol TAB Series Dynamometer Table or dynamometer base plate (depending on model and system configuration)

DESCRIPTION

Magtrol's AMF Series Adjustable Motor Fixtures are used to secure small to medium-sized motors in place while running any test. These extremely versatile fixtures also enable easy motor centering for coupling to a Magtrol HD Series Hysteresis Dynamometer. (Couplings can be supplied upon request.) Various motor lengths are accommodated by either an attached T-slot base plate or sliding base, depending on the model.

The AMF-1, -2 and -3 Fixtures feature one or two adjustable bridges, each fitted with a fluted knob clamp screw, to allow clamping anywhere along the axis of the motor. The adjustable bridge on the AMF-V Fixture incorporates a straight-line action clamp with a V-angle rubber padded clamp to maximize the mounting area.

To safeguard the motor, locking thumb screws provide protection against vibration and all motor-to-fixture contact surfaces are nylon padded for scratch-free clamping.

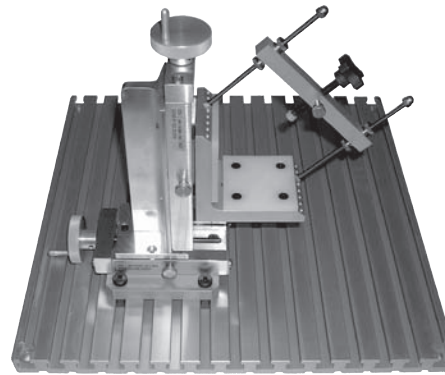

AMF-1

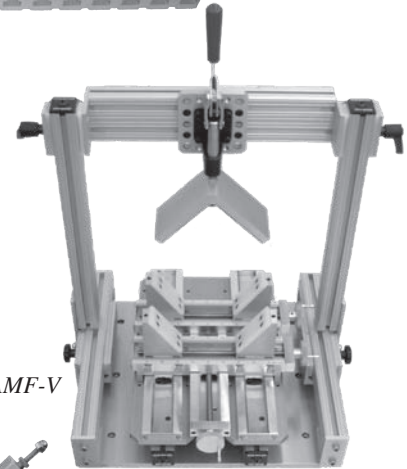

AMF-V

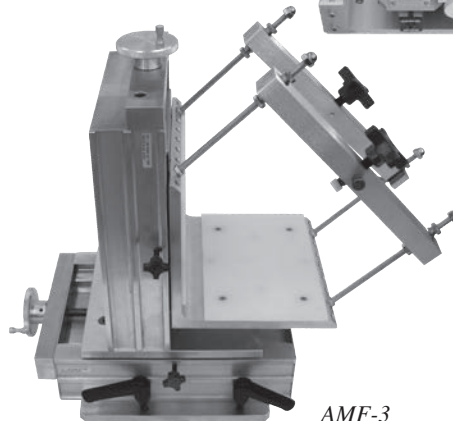

AMF-3

MODEL COMPARISON

	AMF-1	AMF-2	AMF-3	AMF-V
Motor Diameter	up to 4 inches	up to 6 inches	up to 8¼ inches	4 to 8 inches
Dynamometer	HD-100, 400 and 500 Series with short base plate option	HD-700 Series with short base plate option	HD-800 Series with T-slot base plate option	HD-800 Series with T-slot base plate option
Fixture Base	T-slot base plate	T-slot base plate	standard base plate	slider
Clamping Bridges	1	2	2	1
Max. Motor Weight	10 lb (4.5 kg)	100 lb (45 kg)	100 lb (45 kg)	30 lb (13.6 kg)
Max. Motor Torque	20 lb-in (2.25 N·m)	160 lb-in (18 N·m)	250 lb-in (28 N·m)	125 lb-in (14 N·m)
Temp. Range	-18°C (0°F) to 83°C (180°F)	-18°C (0°F) to 83°C (180°F)	-18°C (0°F) to 83°C (180°F)	-18°C (0°F) to 83°C (180°F)

AMF-1

Magtrol HD-100-XXX-0100 Dynamometer and AMF-1 Adjustable Motor Fixture with 2-inch motor locked in place

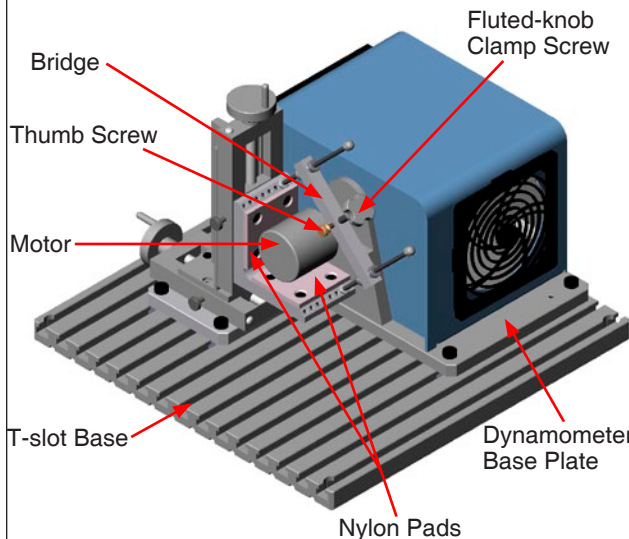

AMF-2

Magtrol HD-705-XXX-0100 Dynamometer and AMF-2 Adjustable Motor Fixture with 4-inch motor locked in place

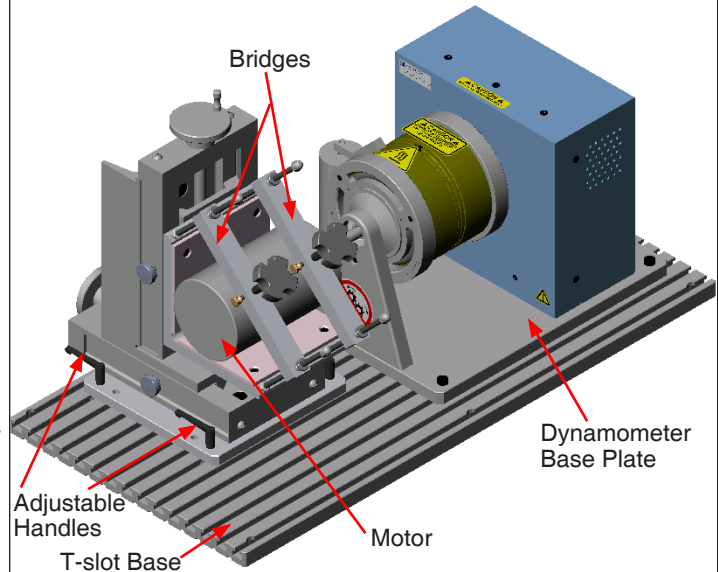

AMF-3

Magtrol HD-815-XXX-0200 Dynamometer and AMF-3 Adjustable Motor Fixture mounted to TAB 0800L Dynamometer Table

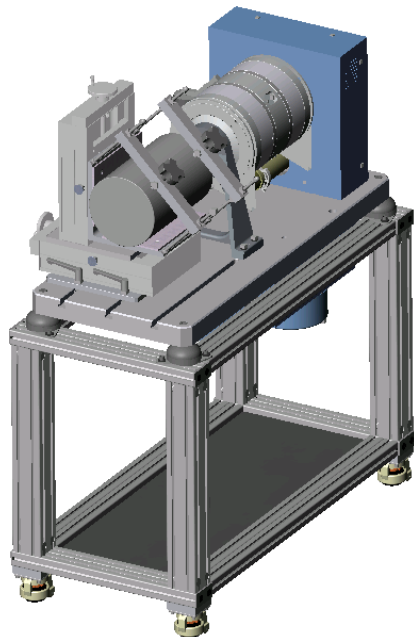

NOTE:
The AMF-3 and AMF-V can also be mounted directly to the HD-825 table (TAB 0825L).

AMF-V

Magtrol HD-815 Dynamometer and AMF-V Adjustable Motor Fixture with 6-inch motor locked in place

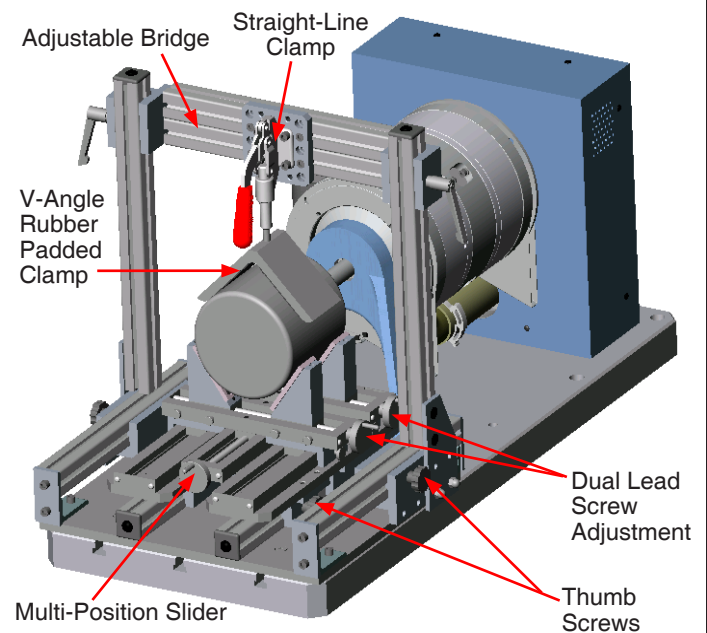

Due to the continual development of our products, we reserve the right to modify specifications without forewarning.



www.magtrol.com

MAGTROL INC

70 Gardenville Parkway
Buffalo, New York 14224 USA
Phone: +1 716 668 5555
Fax: +1 716 668 8705
E-mail: magtrol@magtrol.com

MAGTROL SA

Route de Montena 77
1728 Rossens/Fribourg, Switzerland
Phone: +41 (0)26 407 3000
Fax: +41 (0)26 407 3001
E-mail: magtrol@magtrol.ch

Subsidiaries in:

Germany • France
China • India
Worldwide Network
of Sales Agents

